



**CD-100A**

***LaserStar***<sup>®</sup>  
***Compact Disc  
Phonograph***

---

**Field Service Manual  
& Parts Catalog**

**Volume 2 of 2**

**Troubleshooting**

**PART NO. 21822615  
SECOND EDITION**



Rowe extends to the original operator of this equipment the following warranty:

All parts are guaranteed to be free of defects in material and workmanship for the specific periods which follow. Rowe agrees to repair without charge during such period any part which proves defective upon examination by Rowe. All costs of shipping an allegedly defective part to or from Rowe's offices shall be borne by the original operator.

Phono Mechanism Moving Parts	5 Years
Electronic Circuit Boards	2 Years
Electrical and Mechanical Parts	1 Year
Lamps and Styli	90 Days
CD Players, VCR's, Monitors, and CD Decks	1 Year

In the case of parts supplied to Rowe as components, Rowe extends the same warranty period as extended by the original manufacturer.

The above warranty applies provided that all parts of the machine have been serviced properly as directed in the service manual, and provided the alleged defective part, upon examination by Rowe, shall prove to be thus defective.

This warranty will not apply to any machine or any part which has been subjected to any accident, abuse, or misuse.

ROWE INTERNATIONAL, INC. EXTENDS NO WARRANTY, EXPRESSED OR IMPLIED, TO PURCHASERS OR USERS OF ITS PRODUCTS EXCEPT AS HEREIN SET FORTH, WHETHER BY OPERATION OF LAW OR OTHERWISE.



### **WARNING:**

When servicing, do not approach the laser exit with the eye too closely. In case it is necessary to confirm laser beam emission, be sure to observe from a distance of more than 10 inches from the surface of the objective lens on the optical pick-up block.



### **WARNING:**

This equipment generates, uses, and can radiate radio frequency energy and if not installed and used in accordance with the instructions manual, may cause interference to radio communications. It has been tested and found to comply with the limits for a Class A computing device pursuant to Subpart J of Part 15 of FCC Rules, which are designed to provide reasonable protection against such interference when operated in a commercial environment. Operation of this equipment in a residential area is likely to cause interference in which case the user at his own expense will be required to take whatever measures may be required to correct the interference.

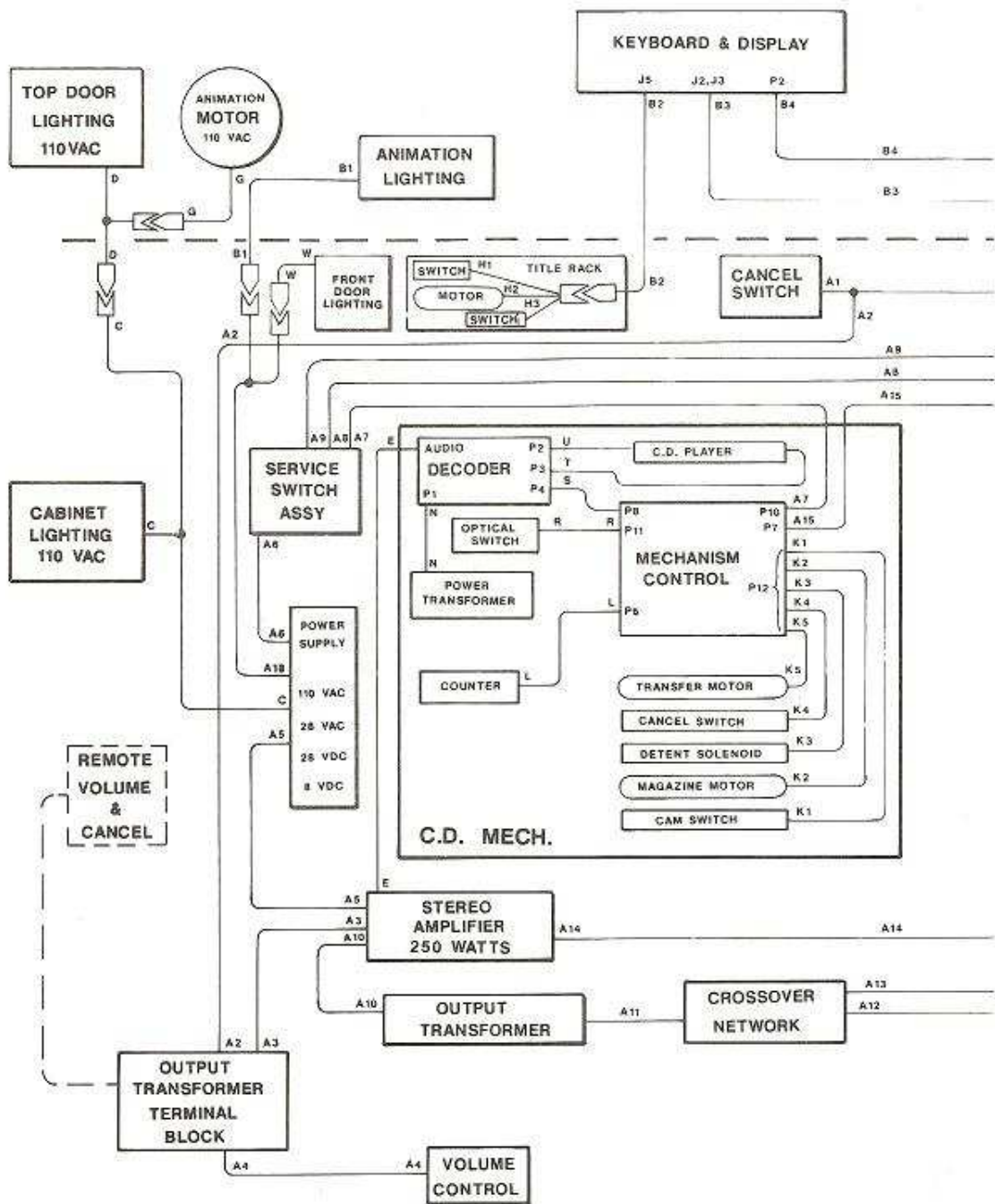



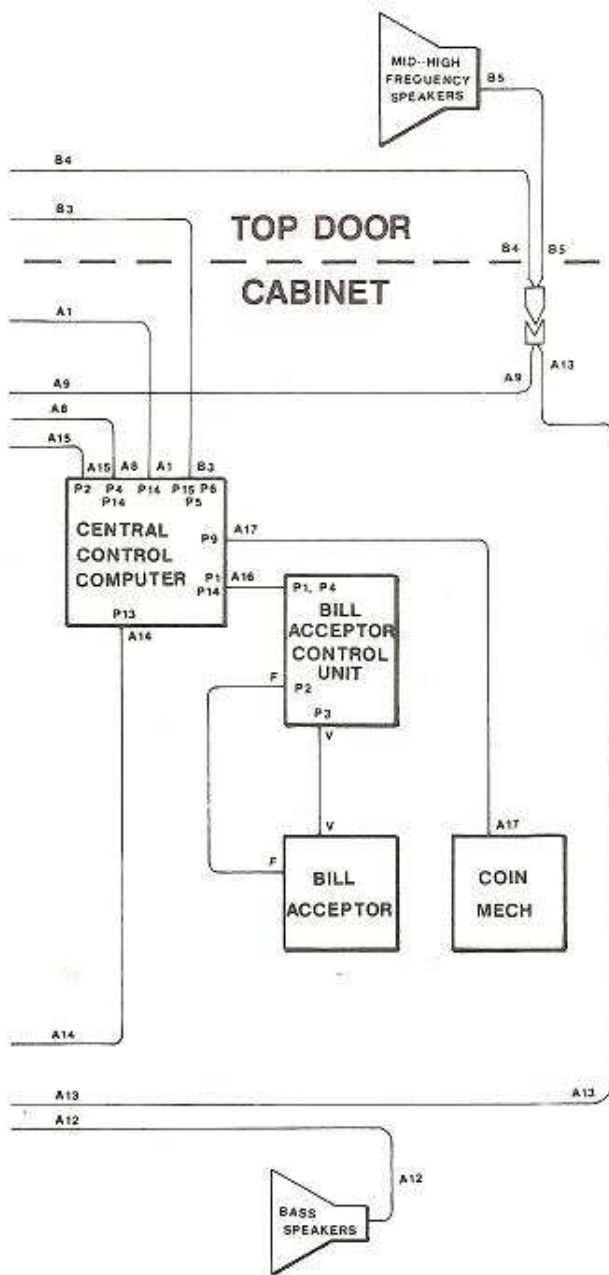

- A > HARNESS & SWITCH ASSY** \_\_\_\_\_ **61035502**
1. CANCEL TO COMPUTER
  2. CANCEL LINE TO TERMINAL BLOCK
  3. REMOTE VOLUME & VOLUME CONTROL FROM AMPLIFIER
  4. VOLUME CONTROL
  5. 110 VAC TO AMPLIFIER
  6. LOW VOLTAGE POWER TO SWITCH
  7. 28 VAC TO C. D. PLAYER
  8. LOW VOLTAGE POWER TO COMPUTER
  9. PAGE CONTROL
  10. AMPLIFIER OUTPUT (AUDIO)
  11. AUDIO OUTPUT TO CROSSOVER
  12. AUDIO OUTPUT TO BASS SPEAKERS
  13. AUDIO OUTPUT TO MID-HIGH FREQUENCY SPEAKERS
  14. MUTE
  15. SIGNAL & VDC POWER TO C.D. PLAYER
  16. SIGNAL & VDC POWER TO CONTROL UNIT
  17. SIGNAL - COIN MECHANISM
  18. 28 VAC POWER TO ANIMATION AND FRONT DOOR LIGHTING
- B > HARNESS ASSY - DISPLAY** \_\_\_\_\_ **40833402**
1. 28 VAC POWER TO ANIMATION LIGHTING
  2. SIGNAL AND VDC POWER TO TITLE RACK
  3. SIGNAL AND VDC POWER TO KEYBOARD / DISPLAY
  4. PAGE CONTROL
  5. AUDIO INPUT TO MID-HIGH FREQUENCY SPEAKERS
- C > HARNESS ASSY -110VAC 60/50 HZ** \_\_\_\_\_ **40832901,02**
- D > HARNESS ASSY-TOP DOOR LIGHTING** \_\_\_\_\_ **40834501**
- E > CABLE ASSY - AUDIO** \_\_\_\_\_ **30934201**
- F > HARNESS ASSY-INTERCONNECT** \_\_\_\_\_ **45070203**
- G > MOTOR & HARNESS ASSY** \_\_\_\_\_ **40824302**
- H > HARNESS ASSY-INTERCONNECT** \_\_\_\_\_ **30938501**
1. SWITCH-SIGNAL TO DISPLAY
  2. SWITCH-SIGNAL TO DISPLAY
  3. VDC POWER FROM DISPLAY
- K > HARNESS ASSY - C. D. MECH,** \_\_\_\_\_ **40830002**
1. CAM SWITCH----- TO MECH CONTROL
  2. MAGAZINE MOTOR-- TO MECH CONTROL
  3. DETENT SOLENOID- TO MECH CONTROL
  4. CANCEL SWITCH--- TO MECH CONTROL
  5. TRANSFER MOTOR-- TO MECH CONTROL
- L > COUNTER & PLUG ASSY** \_\_\_\_\_ **30933301**
- N > TRANSFORMER ASSY-POWER** \_\_\_\_\_ **40830401**
- R > OPTICAL SWITCH ASSY** \_\_\_\_\_ **30906801**
- S > HARNESS ASSY- PLAYER CONTROL** \_\_\_\_\_ **30930501**
- T > HARNESS ASSY-C.D. MECH (SIGNAL)** \_\_\_\_\_ **30930701**
- U > HARNESS ASSY- C.D. MECH (POWER)** \_\_\_\_\_ **30930601**
- V > HARNESS ASSY- D.C. BILL STACKER** \_\_\_\_\_ **45062308**
- W > HARNESS ASSY- DOOR LIGHT** \_\_\_\_\_ **30951701**

Figure 5-4. CD-100A Harness Diagram

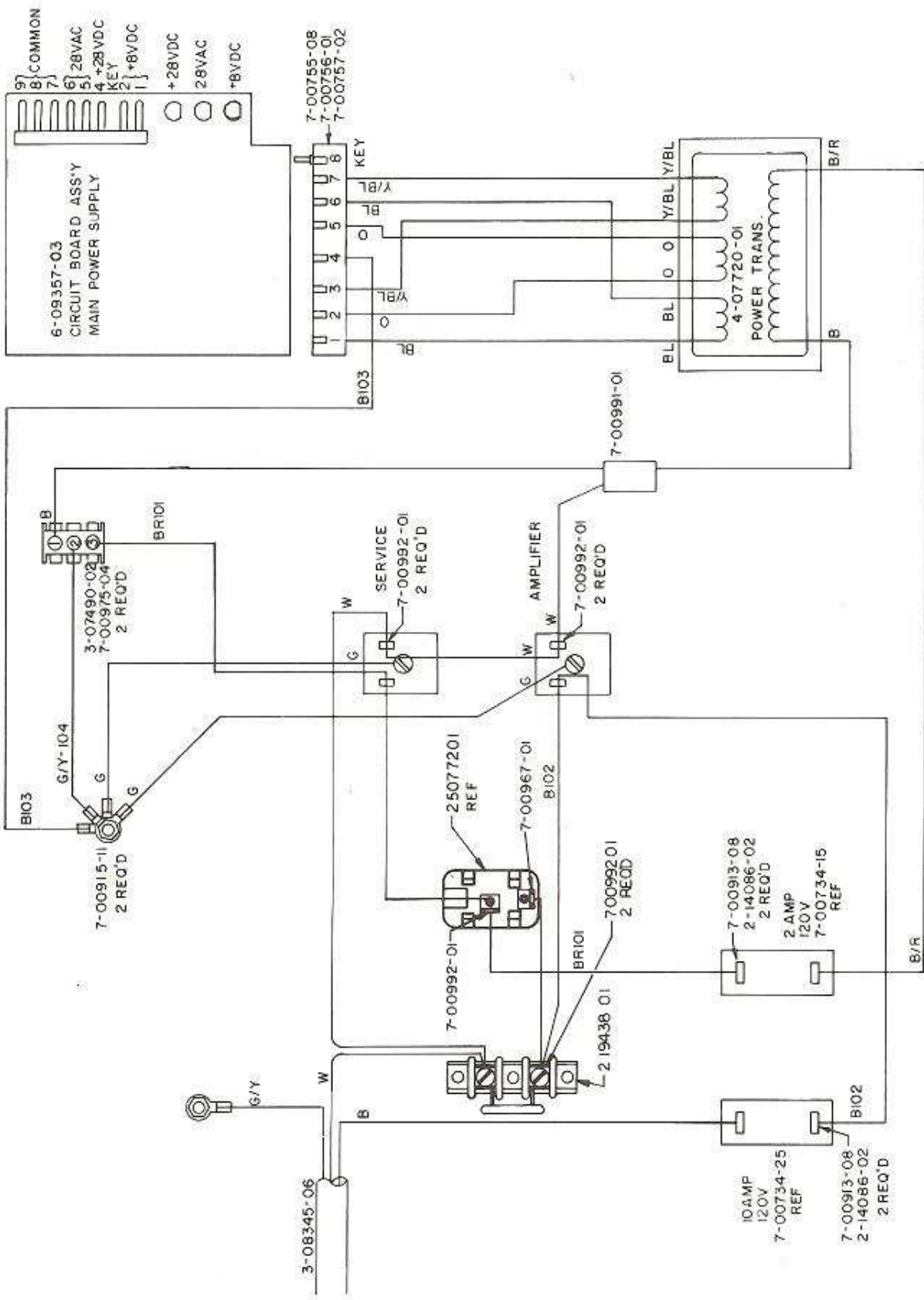

For Equivalent Engineering Drawing See 40770607-Q1 A

Figure 5-5A. Main Power Supply Wiring Diagram - Domestic

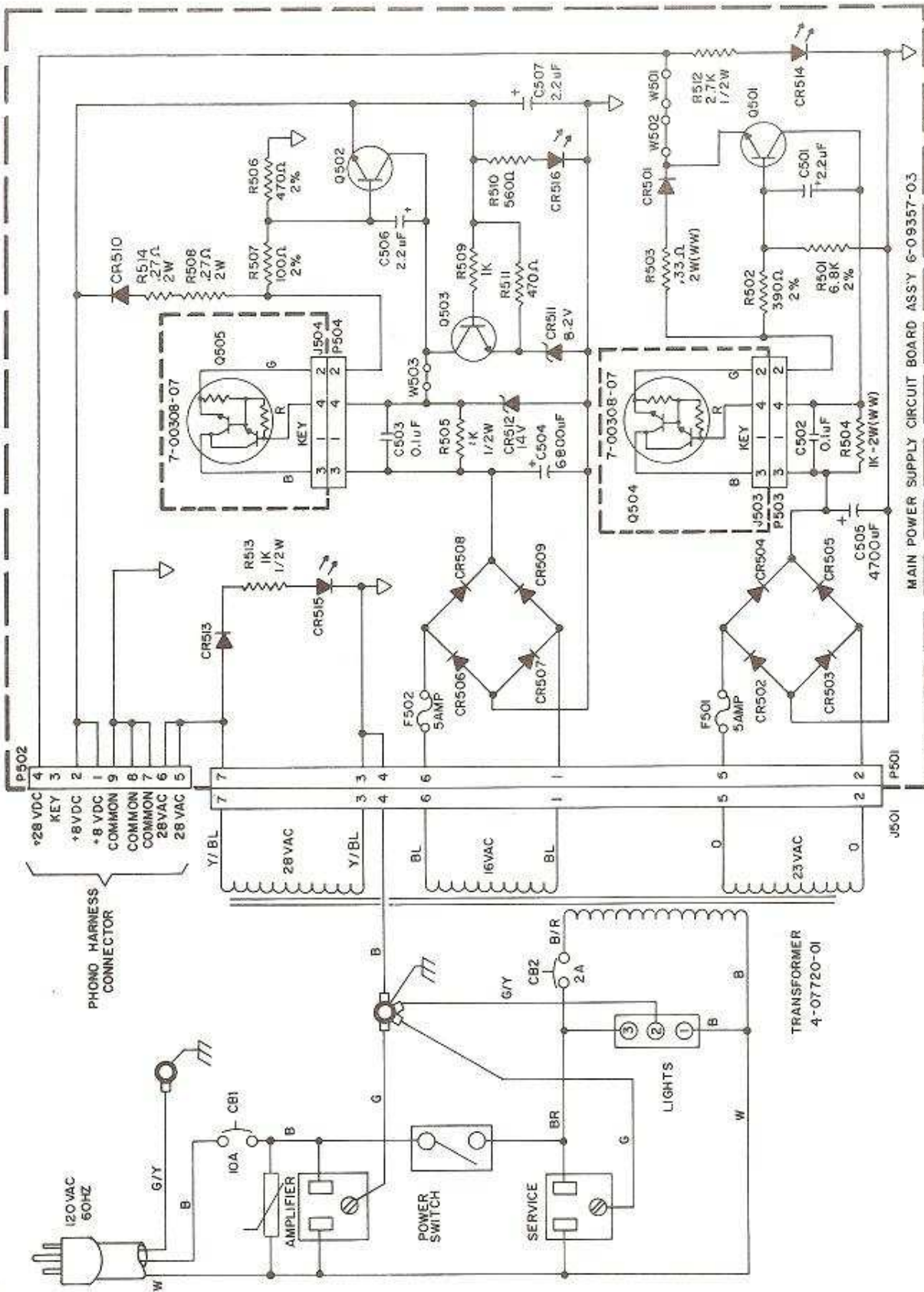

For Equivalent Engineering Drawing See 40770607-02 B

Figure 5-5B. Main Power Supply Schematic - Domestic





25122615

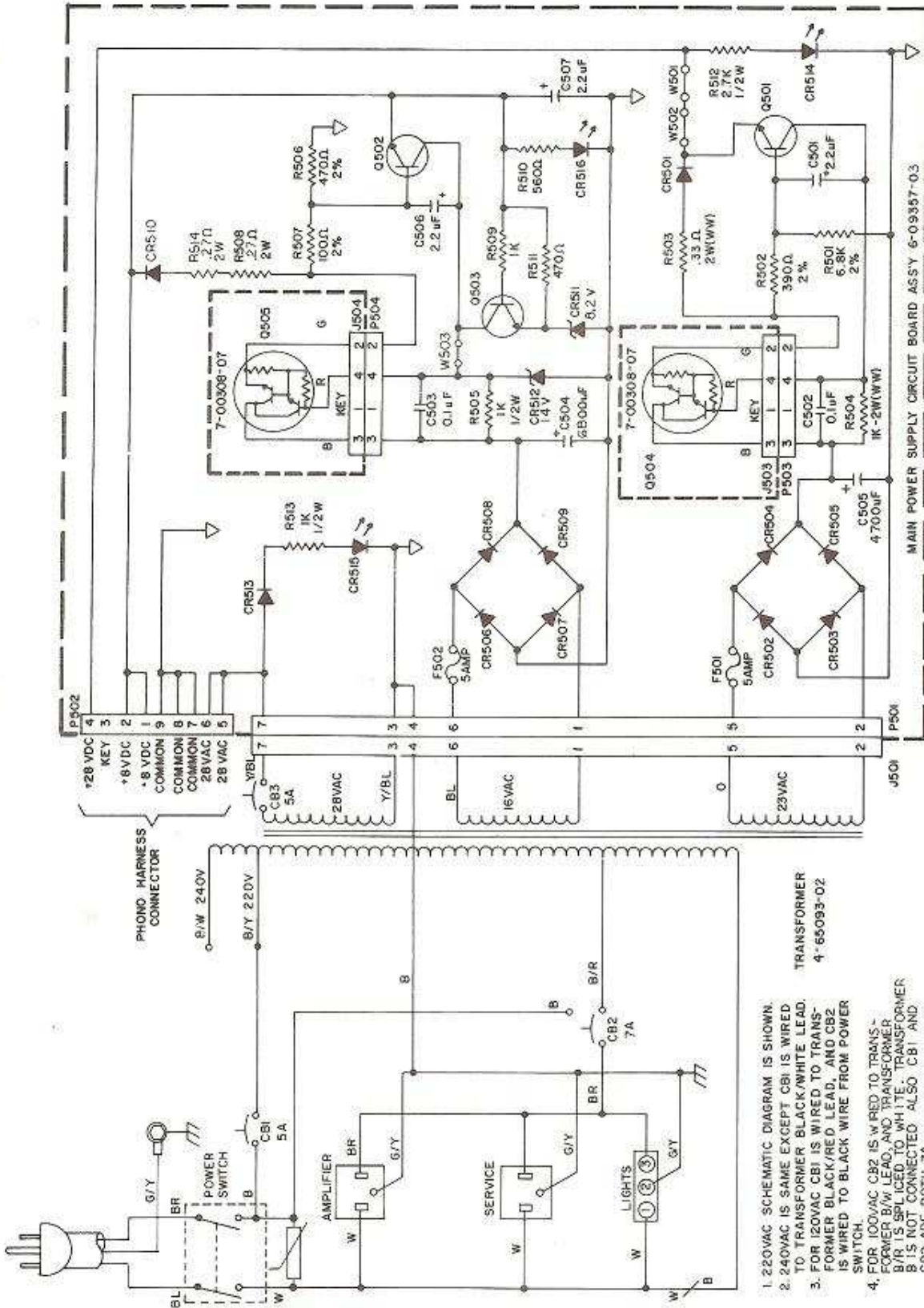

1. 220VAC SCHEMATIC DIAGRAM IS SHOWN.  
 2. 240VAC IS SAME EXCEPT CB1 IS WIRED TO TRANSFORMER BLACK/WHITE LEAD.  
 3. FOR 120VAC CB1 IS WIRED TO TRANSFORMER BLACK/RED LEAD, AND CB2 IS WIRED TO BLACK WIRE FROM POWER SWITCH.  
 4. FOR 100VAC CB2 IS WIRED TO TRANSFORMER B/W LEAD, AND TRANSFORMER B/R IS SUBSTITUTED TO WHITE. TRANSFORMER B IS NOT CONNECTED ALSO. CB1 AND CB2 ARE BOTH 7A.  
 46509309 IS 100VAC  
 46509312 IS 220VAC  
 46509313 IS 240VAC

For Equivalent Engineering Drawing See 46509212/13-02 8

Figure 5-6B. Main Power Supply Schematic - Export



**COMPONENTS LIST FOR  
MAIN POWER SUPPLY CIRCUIT BOARD 60935703**

C501	Capacitor - Electrolytic	2.2 mf @ 50V	70023805
C502	Capacitor - Monolithic Ceramic	0.1 mf @ 50V	70028511
C503	Capacitor - Monolithic Ceramic	0.1 mf @ 50V	70028511
C504	Capacitor - Electrolytic	6800 mf @ 35V	70023601
C505	Capacitor - Electrolytic	4700 mf @ 50V	70023604
C506	Capacitor - Electrolytic	2.2 mf @ 50V	70023805
C507	Capacitor - Electrolytic	2.2 mf @ 50V	70023805
CR501-CR510	Diode - Silicon		70035004
CR511	Diode - Zener (8.2 V, 5%)		70035528
CR512	Diode - Zener (14 V, 5%)		70035529
CR513	Diode - Silicon		70035005
CR514-CR516	Diode - Light Emitting		70035303
F501-F502	Fuse - 5 Amp		70072106
P501	Polarizing Wafer Assembly		70075007
P502	Polarizing Wafer Assembly - Right-angle mount		70076009
P503-P504	Polarizing Wafer Assembly		70075003

Q501-Q502	Transistor - Silicon	(NPN)	70033005
Q503	Transistor - Silicon	(NPN)	70030008

**Note: All resistors are 1/4 watt 5%, unless otherwise noted.**

R501	Resistor - Carbon	6.8 K	(1/4 w, 2%)	79902682
R502	Resistor - Carbon	390 Ohm	(1/4 w, 2%)	79902391
R503	Resistor - Wire Wound	0.33 Ohm	(2 w, 5%)	79920338
R504	Resistor - Wire Wound	1 K	(2 w, 10%)	79920102
R505	Resistor - Carbon	1 K	(1/2 w, 10%)	70010619
R506	Resistor - Carbon	470 Ohm	(1/4 w, 2%)	79902471
R507	Resistor - Carbon	100 Ohm	(1/4 w, 2%)	79902101
R508	Resistor - Wire Wound	0.27 Ohm	(2 w, 5%)	79920278
R509	Resistor - Carbon	1 K	(1/4 w, 5%)	79901102
R510	Resistor - Carbon	560 Ohm	(1/4 w, 5%)	79901561
R511	Resistor - Carbon	470 Ohm	(1/4 w, 5%)	79901471
R512	Resistor - Carbon	2.7 K	(1/2 w, 5%)	70012007
R513	Resistor - Carbon	1 K	(1/2 w, 10%)	70010619
R514	Resistor - Carbon	.27 Ohm	(2 w, 5%)	79920278



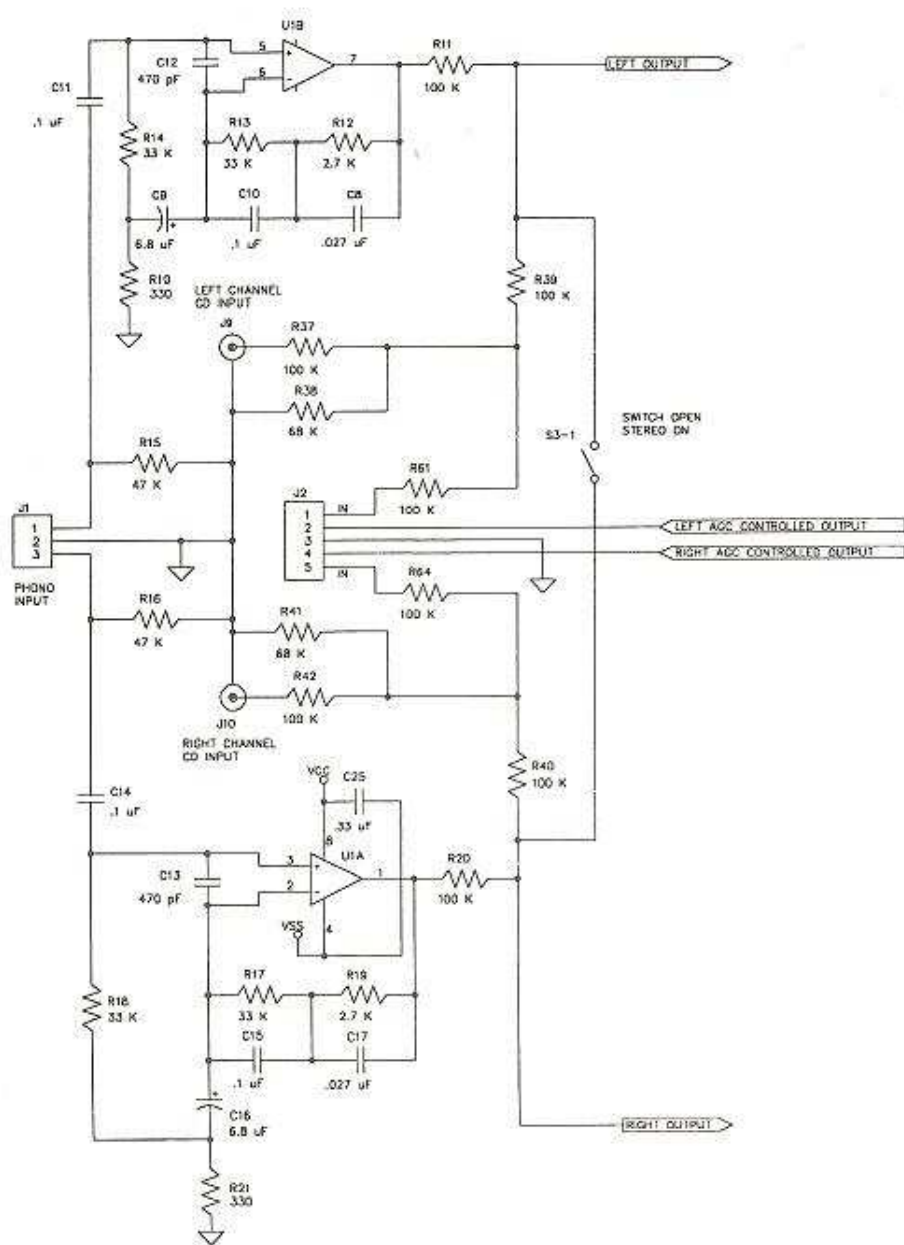

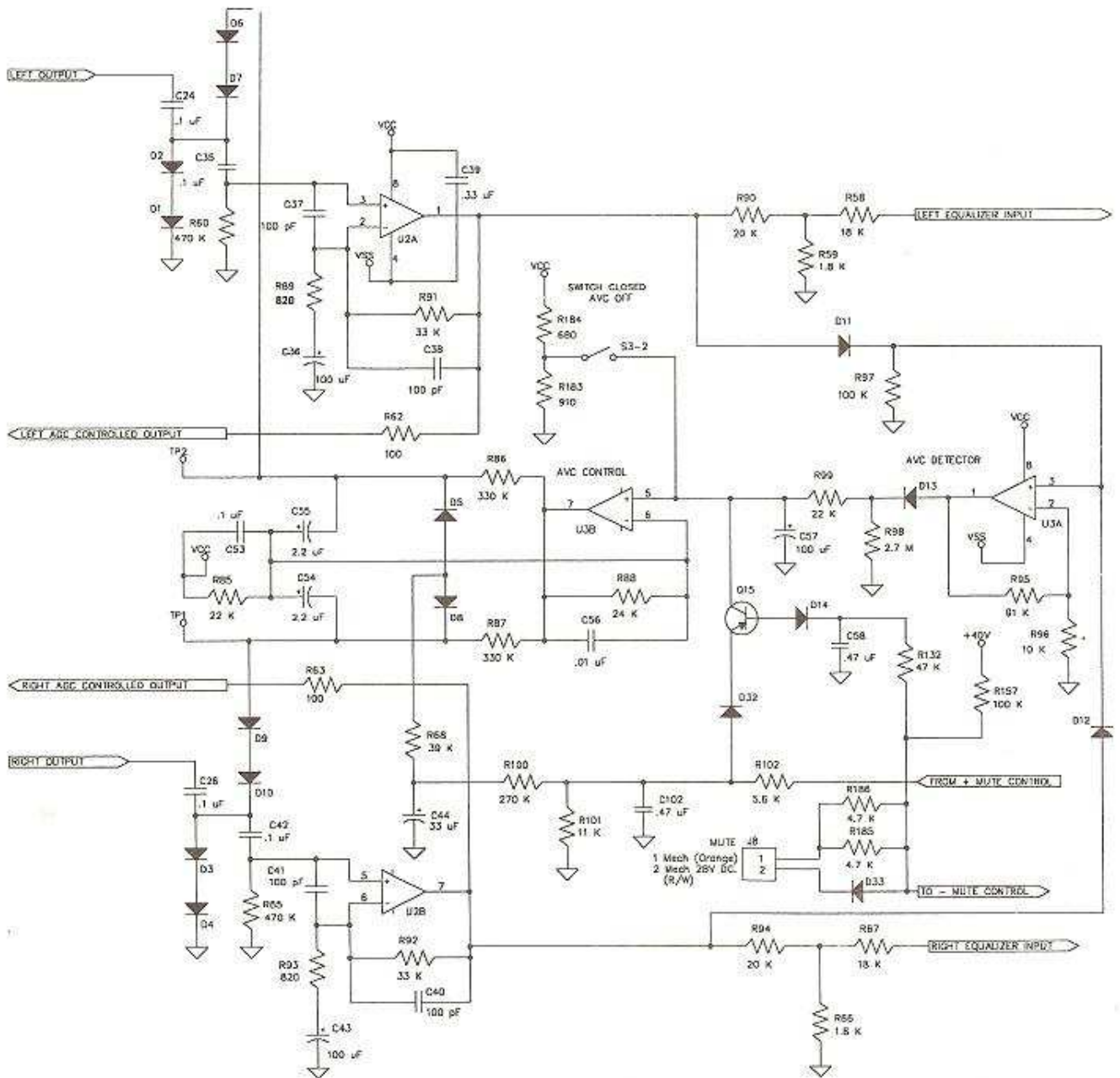

For Equivalent Engineering Drawing See 61023702 B

Figure 5-7A. Schematic Diagram - Stereo Preamp Assembly, Sheet 1



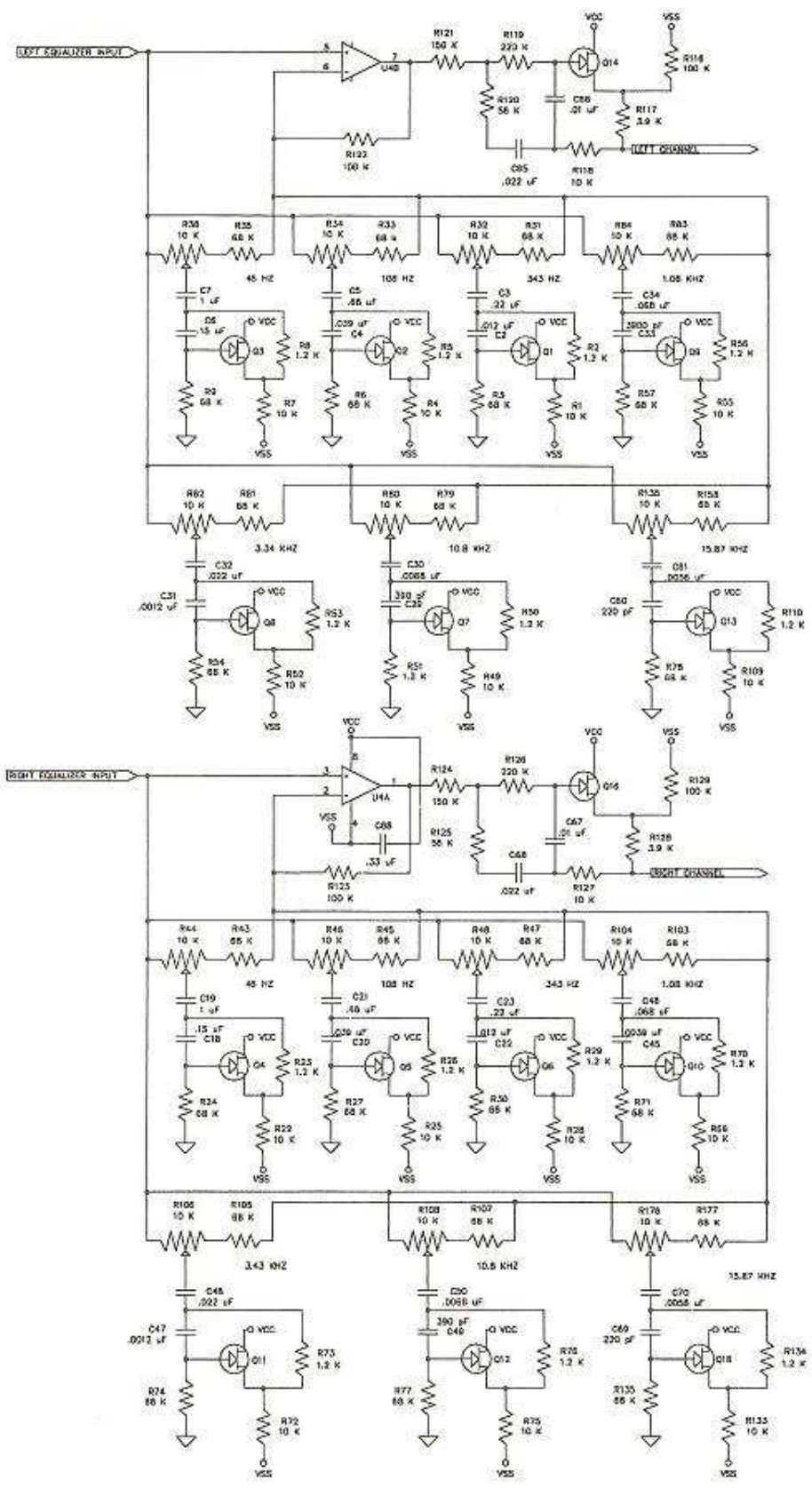

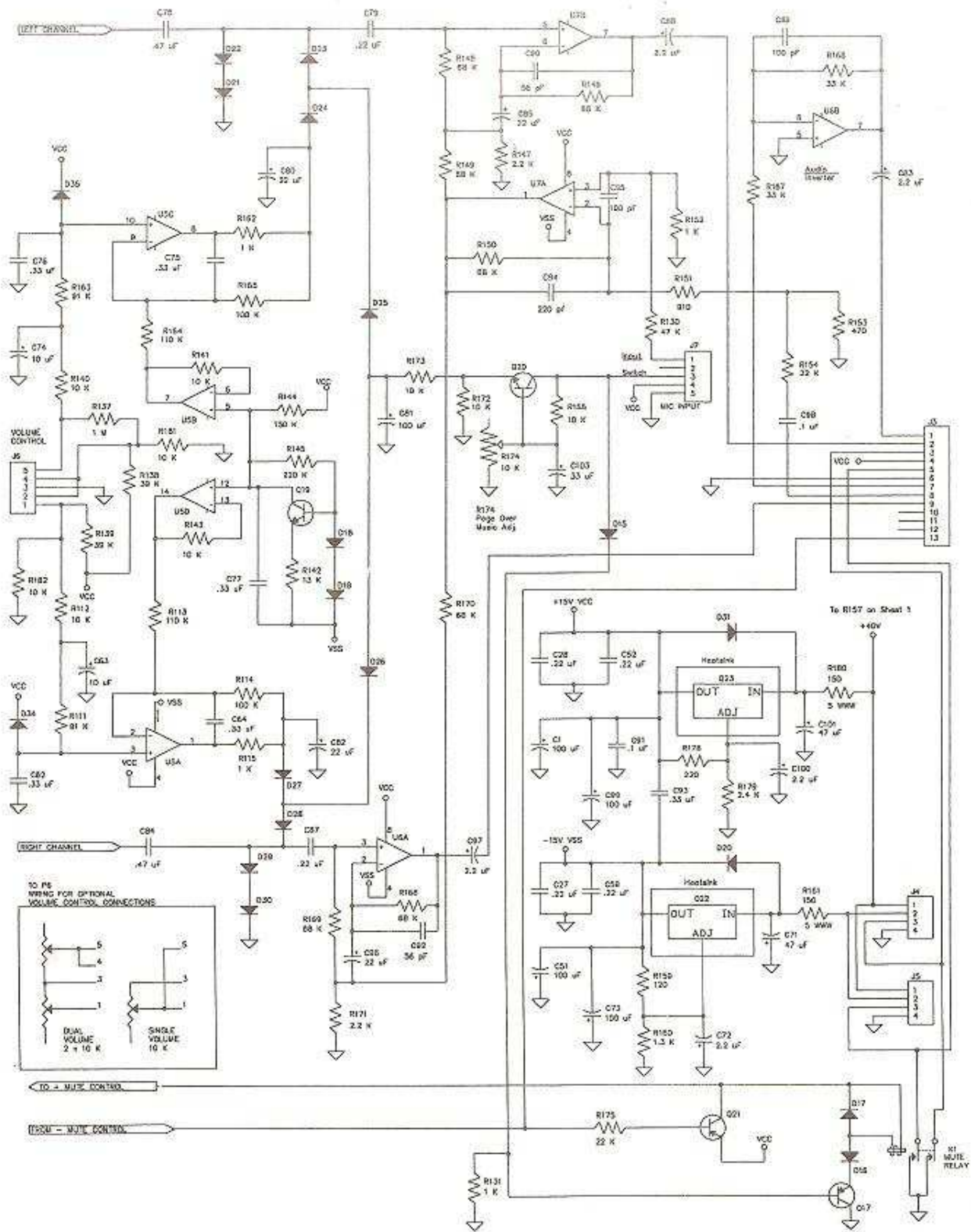

For Equivalent Engineering Drawing See 61023702 B

Figure 5-7A. Schematic Diagram - Stereo Preamp Assembly, Sheet 2



## COMPONENT LIST FOR PREAMPLIFIER BOARD (61023702-B)

C1	Capacitor - Electrolytic	100 mf	70023814
C2	Capacitor - Monolithic Ceramic	.012 mf	70028638
C3	Capacitor - Monolithic Ceramic	.22 mf	70028510
C4	Capacitor - Monolithic Ceramic	.039 mf	70028644
C5	Capacitor - Monolithic Ceramic	.68 mf	70028522
C6	Capacitor - Monolithic Ceramic	.15 mf	70028512
C7	Capacitor - Monolithic Ceramic	1 mf	70028521
C8	Capacitor - Monolithic Ceramic	.027 mf	70028642
C9	Capacitor - Electrolytic	6.8 mf	70023807
C10	Capacitor - Monolithic Ceramic	.1 mf	70028649
C11	Capacitor - Monolithic Ceramic	.1 mf	70028649
C12	Capacitor - Monolithic Ceramic	470 pf	70028612
C13	Capacitor - Monolithic Ceramic	470 pf	70028612
C14	Capacitor - Monolithic Ceramic	.1 mf	70028649
C15	Capacitor - Monolithic Ceramic	.1 mf	70028649
C16	Capacitor - Electrolytic	6.8 mf	70023807
C17	Capacitor - Monolithic Ceramic	.027 mf	70028642
C18	Capacitor - Monolithic Ceramic	.15 mf	70028512
C19	Capacitor - Monolithic Ceramic	1 mf	70028521
C20	Capacitor - Monolithic Ceramic	.039 mf	70028644
C21	Capacitor - Monolithic Ceramic	.68 mf	70028522
C22	Capacitor - Monolithic Ceramic	.012 mf	70028638
C23	Capacitor - Monolithic Ceramic	.22 mf	70028510
C24	Capacitor - Monolithic Ceramic	.1 mf	70028649
C25	Capacitor - Monolithic Ceramic	.33 mf	70028515
C26	Capacitor - Monolithic Ceramic	.1 mf	70028649
C27	Capacitor - Monolithic Ceramic	.22 mf	70028510
C28	Capacitor - Monolithic Ceramic	.22 mf	70028510
C29	Capacitor - Monolithic Ceramic	390 pf	70028611
C30	Capacitor - Monolithic Ceramic	.0068 mf	70028633
C31	Capacitor - Monolithic Ceramic	.0012 mf	70028620
C32	Capacitor - Monolithic Ceramic	.022 mf	70028641
C33	Capacitor - Monolithic Ceramic	.0039 mf	70028629
C34	Capacitor - Monolithic Ceramic	.068 mf	70028647
C35	Capacitor - Monolithic Ceramic	.1 mf	70028649
C36	Capacitor - Electrolytic	100 mf	70023814
C37	Capacitor - Monolithic Ceramic	100 pf	70028601
C38	Capacitor - Monolithic Ceramic	100 pf	70028601
C39	Capacitor - Monolithic Ceramic	.33 mf	70028515
C40	Capacitor - Monolithic Ceramic	100 pf	70028601
C41	Capacitor - Monolithic Ceramic	100 pf	70028601
C42	Capacitor - Monolithic Ceramic	.1 mf	70028649
C43	Capacitor - Electrolytic	100 mf	70023814
C44	Capacitor - Electrolytic	33 mf	70023811
C45	Capacitor - Monolithic Ceramic	.0039 mf	70028629
C46	Capacitor - Monolithic Ceramic	.068 mf	70028647
C47	Capacitor - Monolithic Ceramic	.0012 mf	70028620
C48	Capacitor - Monolithic Ceramic	.022 mf	70028641
C49	Capacitor - Monolithic Ceramic	390 pf	70028611
C50	Capacitor - Monolithic Ceramic	.0056 mf	70028632
C51	Capacitor - Electrolytic	100 mf	70023814

C52	Capacitor - Monolithic Ceramic	.22 mf	70028510
C53	Capacitor - Monolithic Ceramic	.1 mf	70028649
C54	Capacitor - Electrolytic	2.2 mf	70023805
C55	Capacitor - Electrolytic	2.2 mf	70023805
C56	Capacitor - Monolithic Ceramic	.01 mf	70028636
C57	Capacitor - Electrolytic	100 mf	70023814
C58	Capacitor - Electrolytic	2.2 mf	70023805
C59	Capacitor - Monolithic Ceramic	.22 mf	70028510
C60	Capacitor - Monolithic Ceramic	220 pf	70028606
C61	Capacitor - Monolithic Ceramic	.0056 mf	70028632
C62	Capacitor - Monolithic Ceramic	.33 mf	70028515
C63	Capacitor - Electrolytic	10 mf	70023808
C64	Capacitor - Monolithic Ceramic	.33 mf	70028515
C65	Capacitor - Monolithic Ceramic	.022 mf	70028641
C66	Capacitor - Monolithic Ceramic	.01 mf	70028636
C67	Capacitor - Monolithic Ceramic	.01 mf	70028636
C68	Capacitor - Monolithic Ceramic	.022 mf	70028641
C69	Capacitor - Monolithic Ceramic	220 pf	70028606
C70	Capacitor - Monolithic Ceramic	.0056 mf	70028632
C71	Capacitor - Electrolytic	47 mf	70023812
C72	Capacitor - Electrolytic	2.2 mf	70023805
C73	Capacitor - Electrolytic	100 mf	70023814
C74	Capacitor - Electrolytic	10 mf	70023808
C75	Capacitor - Monolithic Ceramic	.33 mf	70028515
C76	Capacitor - Monolithic Ceramic	.33 mf	70028515
C77	Capacitor - Monolithic Ceramic	.33 mf	70028515
C78	Capacitor - Monolithic Ceramic	.47 mf	70028516
C79	Capacitor - Monolithic Ceramic	.22 mf	70028510
C80	Capacitor - Electrolytic	22 mf	70023810
C81	Capacitor - Electrolytic	100 mf	70023814
C82	Capacitor - Electrolytic	22 mf	70023810
C83	Capacitor - Electrolytic	2.2 mf	70023805
C84	Capacitor - Monolithic Ceramic	.47 mf	70028516
C85	Capacitor - Electrolytic	22 mf	70023810
C86	Capacitor - Monolithic Ceramic	.33 mf	70028515
C87	Capacitor - Monolithic Ceramic	.22 mf	70028510
C88	Capacitor - Electrolytic	2.2 mf	70023805
C89	Capacitor - Monolithic Ceramic	100 pf	70028601
C90	Capacitor - Monolithic Ceramic	56 pf	70028710
C91	Capacitor - Monolithic Ceramic	.1 mf	70028649
C92	Capacitor - Monolithic Ceramic	56 pf	70028710
C93	Capacitor - Monolithic Ceramic	.33 mf	70028515
C94	Capacitor - Monolithic Ceramic	220 pf	70028606
C95	Capacitor - Monolithic Ceramic	100 pf	70028601
C96	Capacitor - Electrolytic	22 mf	70023810
C97	Capacitor - Electrolytic	2.2 mf	70023805
C98	Capacitor - Monolithic Ceramic	.1 mf	70028649
C99	Capacitor - Electrolytic	100 mf	70023814
C100	Capacitor - Electrolytic	2.2 mf	70023805
C101	Capacitor - Electrolytic	47 mf	70023812
C102	Capacitor - Monolithic Ceramic	.47 mf	70028516
C103	Capacitor - Electrolytic	33 mf	70023811



# COMPONENT LIST FOR PREAMPLIFIER BOARD

(Continued)

D1	Diode - Silicon	1N4148	70035012
D2	Diode - Silicon	1N4148	70035012
D3	Diode - Silicon	1N4148	70035012
D4	Diode - Silicon	1N4148	70035012
D5	Diode - Silicon	1N4148	70035012
D6	Diode - Silicon	1N4148	70035012
D7	Diode - Silicon	1N4148	70035012
D8	Diode - Silicon	1N4148	70035012
D9	Diode - Silicon	1N4148	70035012
D10	Diode - Silicon	1N4148	70035012
D11	Diode - Silicon	1N4148	70035012
D12	Diode - Silicon	1N4148	70035012
D13	Diode - Silicon	1N4148	70035012
D14	Diode - Silicon	1N4148	70035012
D15	Diode - Silicon	1N4148	70035012
D16	Diode - Silicon	1N4148	70035012
D17	Diode - Silicon	1N4148	70035012
D18	Diode - Silicon	1N4148	70035012
D19	Diode - Silicon	1N4148	70035012
D20	Diode - Silicon	1N4148	70035012
D21	Diode - Silicon	1N4148	70035012
D22	Diode - Silicon	1N4148	70035012
D23	Diode - Silicon	1N4148	70035012
D24	Diode - Silicon	1N4148	70035012
D25	Diode - Silicon	1N4148	70035012
D26	Diode - Silicon	1N4148	70035012
D27	Diode - Silicon	1N4148	70035012
D28	Diode - Silicon	1N4148	70035012
D29	Diode - Silicon	1N4148	70035012
D30	Diode - Silicon	1N4148	70035012
D31	Diode - Silicon	1N4148	70035012
D32	Diode - Silicon	1N4148	70035012
D33	Diode - Silicon	1N4148	70035012
D34	Diode - Silicon	1N4148	70035012
D35	Diode - Silicon	1N4148	70035012
HS1	Heatsink - Vertical Mount		21541405
HS2	Heatsink - Vertical Mount		21541405
P1	Header - Non-Polarizing (3 CKT)		70074921
P2	Header - Non-Polarizing (5 CKT)		70074923
P3	Header - Non-Polarizing (13 CKT)		70074931
P4	Connector - Top Entry (4 CKT)		70074802
P5	Connector - Top Entry (4 CKT)		70074802
P6	Header - Non-Polarizing (5 CKT)		70074923
P7	Header - Non-Polarizing (5 CKT)		70074923
P8	Header - Polarizing (2 CKT)		70075002
P9	Receptacle - Phono Jack		21540902
P10	Receptacle - Phono Jack		21540902
K1	Relay - Reed		70042208

Q1	Transistor - J-FET (N-channel)	2N5484	70030901
Q2	Transistor - J-FET (N-Channel)	2N5484	70030901
Q3	Transistor - J-FET (N-Channel)	2N5484	70030901
Q4	Transistor - J-FET (N-Channel)	2N5484	70030901
Q5	Transistor - J-FET (N-Channel)	2N5484	70030901
Q6	Transistor - J-FET (N-Channel)	2N5484	70030901
Q7	Transistor - J-FET (N-Channel)	2N5484	70030901
Q8	Transistor - J-FET (N-Channel)	2N5484	70030901
Q9	Transistor - J-FET (N-Channel)	2N5484	70030901
Q10	Transistor - J-FET (N-Channel)	2N5484	70030901
Q11	Transistor - J-FET (N-Channel)	2N5484	70030901
Q12	Transistor - J-FET (N-Channel)	2N5484	70030901
Q13	Transistor - J-FET (N-Channel)	2N5484	70030901
Q14	Transistor - J-FET (N-Channel)	2N5484	70030901
Q15	Transistor - Silicon (PNP)	MPSA56	70030104
Q16	Transistor - J-FET (N-Channel)	2N5484	70030901
Q17	Transistor - Silicon (PNP)	MPSA56	70030104
Q18	Transistor - J-FET (N-Channel)	2N5484	70030901
Q19	Transistor - Silicon (NPN)	MPSA06	70030008
Q20	Transistor - Silicon (NPN)	MPSA06	70030008
Q21	Transistor - Silicon (PNP)	MPSA56	70030104
Q22	Regulator - Voltage (ADJ NEG)	LM337T	70036508
Q23	Regulator - Voltage (ADJ POS)	LM317T	70036507

Note: All resistors are 1/4 watt 5%, unless otherwise noted.

R1	Resistor - Carbon	10 K	79901103
R2	Resistor - Carbon	1.2 K	79901122
R3	Resistor - Carbon	68 K	79901683
R4	Resistor - Carbon	10 K	79901103
R5	Resistor - Carbon	1.2 K	79901122
R6	Resistor - Carbon	68 K	79901683
R7	Resistor - Carbon	10 K	79901103
R8	Resistor - Carbon	1.2 K	79901122
R9	Resistor - Carbon	68 K	79901683
R10	Resistor - Carbon	330 Ohm	79901331
R11	Resistor - Carbon	100 K	79901104
R12	Resistor - Carbon	2.7 K	79901272
R13	Resistor - Carbon	33 K	79901333
R14	Resistor - Carbon	33 K	79901333
R15	Resistor - Carbon	47 K	79901473
R16	Resistor - Carbon	47 K	79901473
R17	Resistor - Carbon	33 K	79901333
R18	Resistor - Carbon	33 K	79901333
R19	Resistor - Carbon	2.7 K	79901272
R20	Resistor - Carbon	100 K	79901104
R21	Resistor - Carbon	330 Ohm	79901331
R22	Resistor - Carbon	10 K	79901103
R23	Resistor - Carbon	1.2 K	79901122
R24	Resistor - Carbon	68 K	79901683
R25	Resistor - Carbon	10 K	79901103



# COMPONENT LIST FOR PREAMPLIFIER BOARD

(Continued)

R26	Resistor - Carbon	1.2 K	79901122
R27	Resistor - Carbon	68 K	79901683
R28	Resistor - Carbon	10 K	79901103
R29	Resistor - Carbon	1.2 K	79901122
R30	Resistor - Carbon	68 K	79901683
R31	Resistor - Carbon	68 K	79901683
R32	Potentiometer - Special	10 K	70040018
R33	Resistor - Carbon	68 K	79901683
R34	Potentiometer - Special	10 K	70040018
R35	Resistor - Carbon	68 K	79901683
R36	Potentiometer - Special	10 K	70040018
R37	Resistor - Carbon	100 K	79901104
R38	Resistor - Carbon	68 K	79901683
R39	Resistor - Carbon	100 K	79901104
R40	Resistor - Carbon	100 K	79901104
R41	Resistor - Carbon	68 K	79901683
R42	Resistor - Carbon	100 K	79901104
R43	Resistor - Carbon	68 K	79901683
R44	Potentiometer - Special	10 K	70040018
R45	Resistor - Carbon	68 K	79901683
R46	Potentiometer - Special	10 K	70040018
R47	Resistor - Carbon	68 K	79901683
R48	Potentiometer - Special	10 K	70040018
R49	Resistor - Carbon	10 K	79901103
R50	Resistor - Carbon	1.2 K	79901122
R51	Resistor - Carbon	68 K	79901683
R52	Resistor - Carbon	10 K	79901103
R53	Resistor - Carbon	1.2 K	79901122
R54	Resistor - Carbon	68 K	79901683
R55	Resistor - Carbon	10 K	79901103
R56	Resistor - Carbon	1.2 K	79901122
R57	Resistor - Carbon	68 K	79901683
R58	Resistor - Carbon	18 K	79901183
R59	Resistor - Carbon	1.8 K	79901182
R60	Resistor - Carbon	470 K	79901474
R61	Resistor - Carbon	100 K	79901104
R62	Resistor - Carbon	100 Ohm	79901101
R63	Resistor - Carbon	100 Ohm	79901101
R64	Resistor - Carbon	100 K	79901104
R65	Resistor - Carbon	470 K	79901474
R66	Resistor - Carbon	1.8 K	79901182
R67	Resistor - Carbon	18 K	79901183
R68	Resistor - Carbon	39 K	79901393
R69	Resistor - Carbon	10 K	79901103
R70	Resistor - Carbon	1.2 K	79901122
R71	Resistor - Carbon	68 K	79901683
R72	Resistor - Carbon	10 K	79901103
R73	Resistor - Carbon	1.2 K	79901122
R74	Resistor - Carbon	68 K	79901683
R75	Resistor - Carbon	10 K	79901103
R76	Resistor - Carbon	1.2 K	79901122



R77	Resistor - Carbon	68 K	79901683
R78	Resistor - Carbon	68 K	79901683
R79	Resistor - Carbon	68 K	79901683
R80	Potentiometer - Special	10 K	70040018
R81	Resistor - Carbon	68 K	79901683
R82	Potentiometer - Special	10 K	70040018
R83	Resistor - Carbon	68 K	79901683
R84	Potentiometer - Special	10 K	70040018
R85	Resistor - Carbon	22 K	79901223
R86	Resistor - Carbon	330 K	79901334
R87	Resistor - Carbon	330 K	79901334
R88	Resistor - Carbon	24 K	79901243
R89	Resistor - Carbon	820 Ohm	79901821
R90	Resistor - Carbon	20 K	79901203
R91	Resistor - Carbon	33 K	79901333
R92	Resistor - Carbon	33 K	79901333
R93	Resistor - Carbon	820 Ohm	79901821
R94	Resistor - Carbon	20 K	79901203
R95	Resistor - Carbon	91 K	79901913
R96	Resistor - Carbon	10 K	79901103
R97	Resistor - Carbon	100 K	79901104
R98	Resistor - Carbon	2.7 M	79901275
R99	Resistor - Carbon	22 K	79901223
R100	Resistor - Carbon	270 K	79901274
R101	Resistor - Carbon	11 K	79901113
R102	Resistor - Carbon	5.6 K	79901562
R103	Resistor - Carbon	68 K	79901683
R104	Potentiometer - Special	10 K	70040018
R105	Resistor - Carbon	68 K	79901683
R106	Potentiometer - Special	10 K	70040018
R107	Resistor - Carbon	68 K	79901683
R108	Potentiometer - Special	10 K	70040018
R109	Resistor - Carbon	10 K	79901103
R110	Resistor - Carbon	1.2 K	79901122
R111	Resistor - Carbon	91 K	79901913
R112	Resistor - Carbon	10 K	79901103
R113	Resistor - Carbon	110 K	79901114
R114	Resistor - Carbon	100 K	79901104
R115	Resistor - Carbon	1 K	79901102
R116	Resistor - Carbon	100 K	79901104
R117	Resistor - Carbon	3.9 K	79901392
R118	Resistor - Carbon	10 K	79901103
R119	Resistor - Carbon	220 K	79901224
R120	Resistor - Carbon	56 K	79901563
R121	Resistor - Carbon	150 K	79901154
R122	Resistor - Carbon	100 K	79901104
R123	Resistor - Carbon	100 K	79901104
R124	Resistor - Carbon	150 K	79901154
R125	Resistor - Carbon	56 K	79901563
R126	Resistor - Carbon	220 K	79901224
R127	Resistor - Carbon	10 K	79901103

# COMPONENT LIST FOR PREAMPLIFIER BOARD

(Continued)

R128	Resistor - Carbon	3.9 K	79901392
R129	Resistor - Carbon	100 K	79901104
R130	Resistor - Carbon	47 K	79901473
R131	Resistor - Carbon	1 K	79901102
R132	Resistor - Carbon	47 K	79901473
R133	Resistor - Carbon	10 K	79901103
R134	Resistor - Carbon	1.2 K	79901122
R135	Resistor - Carbon	68 K	79901683
R136	Potentiometer - Special	10 K	70040018
R137	Resistor - Carbon	1 M	79901105
R138	Resistor - Carbon	39 K	79901393
R139	Resistor - Carbon	39 K	79901393
R140	Resistor - Carbon	10 K	79901103
R141	Resistor - Carbon	10 K	79901103
R142	Resistor - Carbon	13 K	79901133
R143	Resistor - Carbon	10 K	79901103
R144	Resistor - Carbon	150 K	79901154
R145	Resistor - Carbon	220 K	79901224
R146	Resistor - Carbon	68 K	79901683
R147	Resistor - Carbon	2.2 K	79901222
R148	Resistor - Carbon	68 K	79901683
R149	Resistor - Carbon	68 K	79901683
R150	Resistor - Carbon	68 K	79901683
R151	Resistor - Carbon	910 Ohm	79901911
R152	Resistor - Carbon	1 K	79901102
R153	Resistor - Carbon	470 Ohm	79901471
R154	Resistor - Carbon	22 K	79901223
R155	Resistor - Carbon	10 K	79901103
R156	NOT USED		
R157	Resistor - Carbon	100 K	79901104
R158	Resistor - Carbon	68 K	79901683
R159	Resistor - Carbon	120 Ohm (1/4 W, 2%)	71102121
R160	Resistor - Carbon	1.3 K (1/4 W, 2%)	79902132
R161	Resistor - Wirewound	150 Ohm (5 Watt)	70012510
R162	Resistor - Carbon	1 K	79901102
R163	Resistor - Carbon	91 K	79901913
R164	Resistor - Carbon	110 K	79901114
R165	Resistor - Carbon	100 K	79901104
R166	Resistor - Carbon	33 K	79901333
R167	Resistor - Carbon	33 K	79901333
R168	Resistor - Carbon	68 K	79901683
R169	Resistor - Carbon	68 K	79901683
R170	Resistor - Carbon	68 K	79901683
R171	Resistor - Carbon	2.2 K	79901222
R172	Resistor - Carbon	10 K	79901103
R173	Resistor - Carbon	10 K	79901103
R174	Potentiometer	10 K	70040014
R175	Resistor - Carbon	22 K	79901223
R176	Potentiometer - Special	10 K	70040018
R177	Resistor - Carbon	68 K	79901683
R178	Resistor - Carbon	220 Ohm (1/4 W, 2%)	79902221



R179	Resistor - Carbon	2.4 K (1/4 W, 2%)	79902242
R180	Resistor - Wirewound	150 Ohm (5 Watt)	70012510
R181	Resistor -Carbon	10 K	79901103
R182	Resistor -Carbon	10 K	79901103
R183	Resistor - Carbon	910 Ohm	79901911
R184	Resistor - Carbon	680 Ohm	79901681
R185	Resistor - Carbon	4.7 K	79901472
R186	Resistor - Carbon	4.7 K	79901472
S3	Switch - DIP		70043302 OR 70042902
U1	IC - Dual OP Amp. (LM833 or XR1458/4558)		30800238
U2	IC - Dual OP Amp. (LM833 or XR1458/4558)		30800238
U3	IC - Dual OP Amp. (LM833 or XR1458/4558)		30800238
U4	IC - Dual OP Amp. (LM833 or XR1458/4558)		30800238
U5	IC - Quad OP Amp. (LM348 or XR-4741)		30800215
U6	IC - Dual OP Amp. (LM833 or XR1458/4558)		30800238
U7	IC - Dual OP Amp. (LM833 or XR1458/4558)		30800238

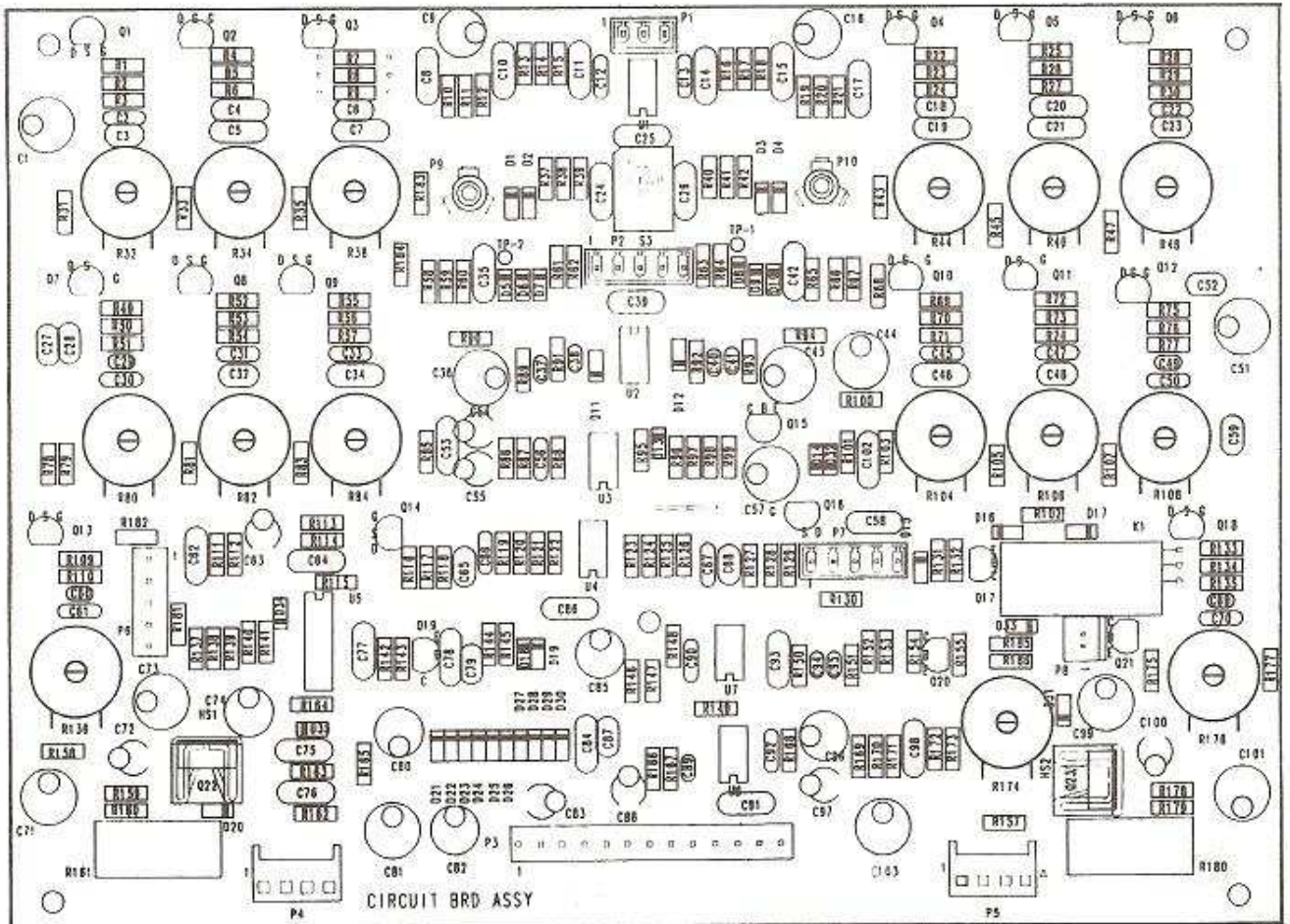
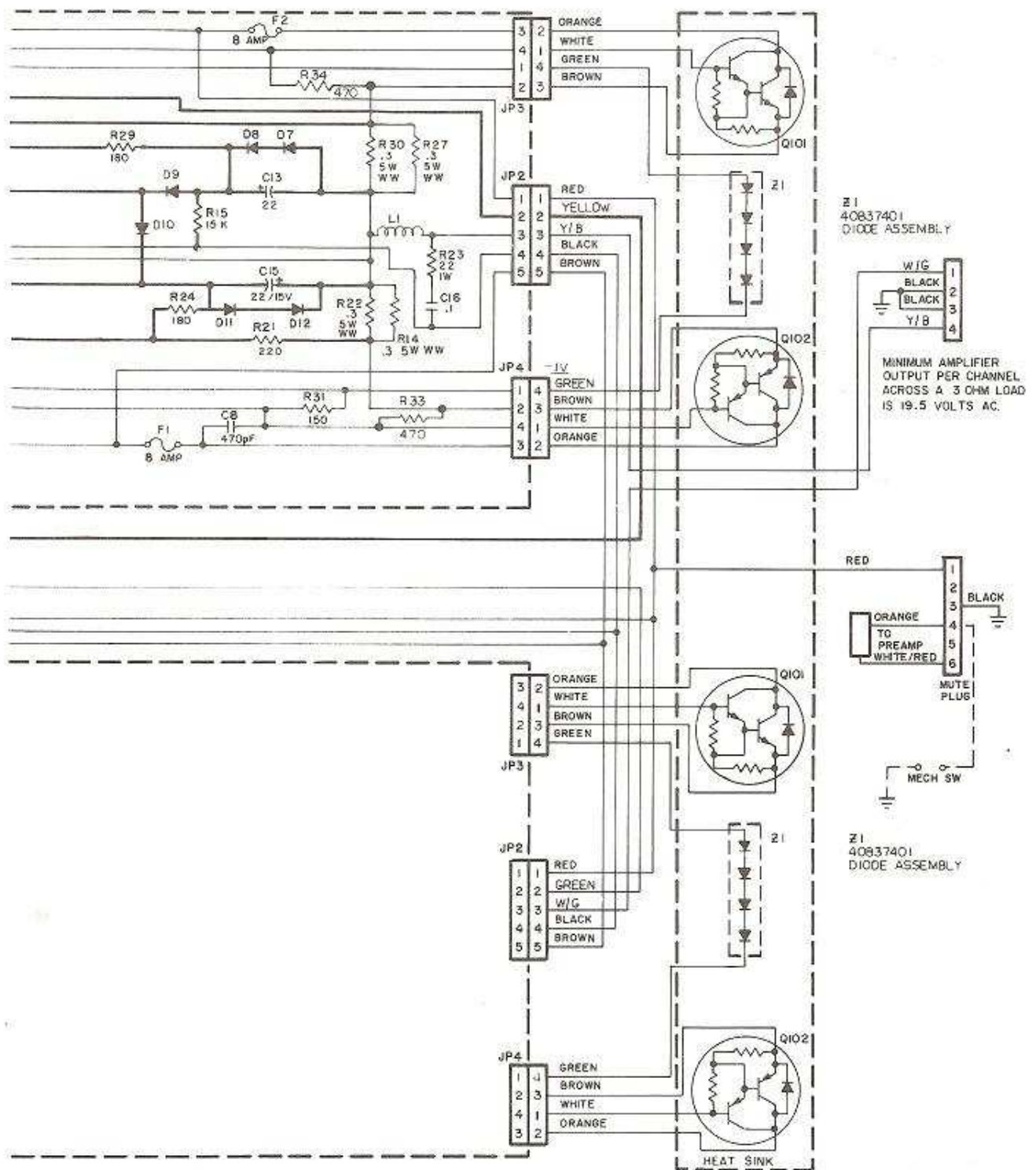

Figure 5-7B. Preamplifier Circuit Board Layout







(See Figure 8-15 for the pictorial view of the heat sink)

For Equivalent Engineering Drawing See 61024901/02-Q2 D

Figure 5-8A. Schematic Diagram - 250 Watt Power Amp

# COMPONENT LIST FOR AMPLIFIER DRIVER BOARD 40710104-K

C1	Capacitor - Mylar	.1 mf	70021549
C2	Capacitor - Mylar	.1 mf	70021549
C3	Capacitor - Monolithic Ceramic	220 pf	70028606
C4	Capacitor - Electrolytic	1 mf	70023804
C5	Capacitor - Electrolytic	47 mf	70023812
C6	Capacitor - Electrolytic	10 mf	70023808
C7	Capacitor - Electrolytic	47 mf	70023812
C8	Capacitor - Monolithic Ceramic	470 pf	70028612
C9	NOT USED		
C10	Capacitor - Monolithic Ceramic	.001 mf	70028618
C11	Capacitor - Monolithic Ceramic	100 pf	70028601
C12	Capacitor - Monolithic Ceramic	220 pf	70028606
C13	Capacitor - Electrolytic	22 mf	70023810
C14	Capacitor - Monolithic Ceramic	.01 mf	70028636
C15	Capacitor - Electrolytic	22 mf	70023810
C16	Capacitor - Mylar	.1 mf	70021549
CR1	Diode - Silicon		70035005
CR2	Diode - Silicon		70035005
CR3	Diode - Zener	(5.1 V)	70035527
CR4	Diode - Zener	(5.1 V)	70035527
CR5	Diode - Zener	(10 V)	70035514
CR6	Diode - Silicon		70035005
CR7	Diode - Silicon		70035005
CR8	Diode - Silicon		70035005
CR9	Diode - Silicon		70035005
CR10	Diode - Silicon		70035005
CR11	Diode - Silicon		70035005
CR12	Diode - Silicon		70035005
CR13	Diode - Silicon		70035005
F1	Fuse (8 Amp)		70072002
F2	Fuse (8 Amp)		70072002
L1	Inductor - Coil		21940701
P1	Wafer - Non-Polarizing	(4 CKT)	70074904
P2	Wafer - Polarizing	(5 CKT)	70075005
P3	Wafer - Polarizing	(4 CKT)	70075004
P4	Wafer - Polarizing	(4 CKT)	70075004
Q1	Transistor - Silicon (Dual)	(NPN)	70030301
Q2	Transistor - Silicon	(NPN)	70030008
Q3	Transistor - Silicon	(NPN)	70033006
Q4	Transistor - Silicon	(PNP)	70030104
Q5	Transistor - Silicon	(PNP)	70030104
Q6	Transistor - Silicon	(PNP)	70030403
Q7	Transistor - Silicon	(NPN)	70030008



Note: All resistors are 1/4 watt 5%, unless otherwise noted.

R1	Resistor - Carbon	18 K	79901183
R2	Resistor - Carbon	220 K	79901224
R3	Resistor - Carbon	18 K	79901183
R4	Resistor - Carbon	5.6 K	79901562
R5	Resistor - Carbon	18 K	79901183
R6	Resistor - Carbon	470 Ohm	79901471
R7	Resistor - Carbon	2.2 K	79901222
R8	Resistor - Carbon	15 K	79901153
R9	Resistor - Carbon	470 Ohm	79901471
R10	Resistor - Carbon	1.5 K	79901152
R11	Resistor - Carbon	2.2 K	79901222
R12	Resistor - Potentiometer	10 K	70040014
R13	Resistor - Carbon	100 Ohm	79901101
R14	Resistor - Wire Wound	.3 Ohm	70011805
R15	Resistor - Carbon	15 K	79901153
R16	Resistor - Carbon	15 K	79901153
R17	Resistor - Carbon	2.2 K	79901222
R18	Resistor - Carbon	820 Ohm	79901821
R19	Resistor - Carbon	47 Ohm	79901470
R20	Resistor - Carbon	15 Ohm	79901150
R21	Resistor - Carbon	180 Ohm	79901181
R22	Resistor - Wire Wound	.3 Ohm	70011805
R23	Resistor - Wire Wound	22 Ohm	79920220
R24	Resistor - Carbon	180 Ohm	79901181
R25	Resistor - Carbon	47 Ohm	79901470
R26	Resistor - Carbon	47 Ohm	79901470
R27	Resistor - Wire Wound	.3 Ohm (5 W, 10%)	70011805
R28	Resistor - Carbon	180 Ohm	79901181
R29	Resistor - Carbon	180 Ohm	79901181
R30	Resistor - Wire Wound	.3 Ohm (5 W, 10%)	70011805
R31	Resistor - Carbon	220 Ohm	79901221
R32	Resistor - Carbon	4.7 K	79901472
R33	Resistor - Carbon	470 Ohm	79901471
R34	Resistor - Carbon	470 Ohm	79901471

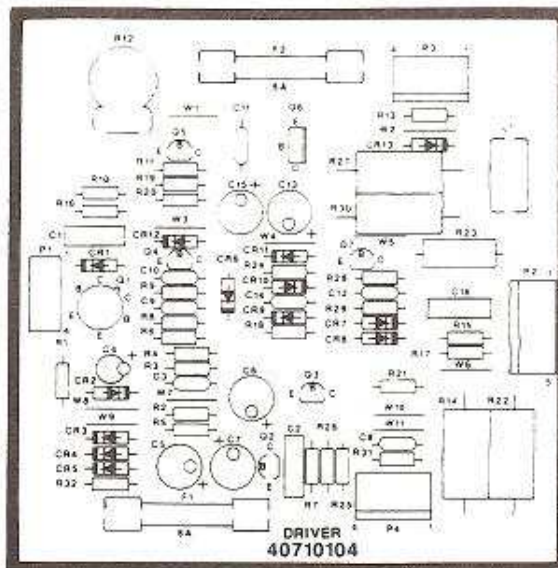
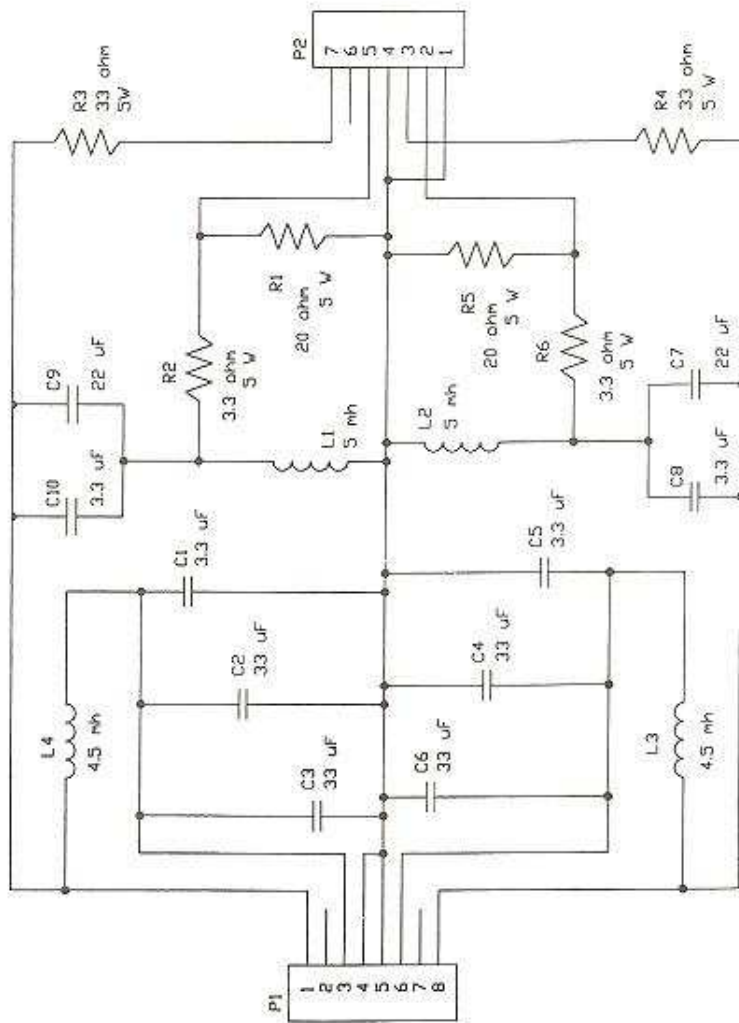

Figure 5-8B. Amplifier Driver Board Layout



For Equivalent Engineering Drawing See 61052701-Q2 A

Figure 5-8C. Schematic Diagram - Crossover Network

**COMPONENTS LIST FOR  
CROSSOVER NETWORK (61052701)**

C1	Capacitor - Bi-Polar Electrolytic	3.3 uF	70022801
C2	Capacitor - Bi-Polar Electrolytic	33 uF	70022811
C3	Capacitor - Bi-Polar Electrolytic	33 uF	70022811
C4	Capacitor - Bi-Polar Electrolytic	33 uF	70022811
C5	Capacitor - Bi-Polar Electrolytic	3.3 uF	70022801
C6	Capacitor - Bi-Polar Electrolytic	33 uF	70022811
C7	Capacitor - Bi-Polar Electrolytic	22 uF	70022809
C8	Capacitor - Bi-Polar Electrolytic	3.3 uF	70022801
C9	Capacitor - Bi-Polar Electrolytic	22 uF	70022809
C10	Capacitor - Bi-Polar Electrolytic	3.3 uF	70022801
L1	Inductor	5 mH	70041302
L2	Inductor	5 mH	70041302
L3	Inductor	4.5 mH	70041301
L4	Inductor	4.5 mH	70041301
P1	Header - Vertical Polarized (8 CKT)		70075008
P2	Header - Vertical Polarized (7 CKT)		70075007
R1	Resistor - Wire Wound 5W	20 $\Omega$	70012514
R2	Resistor - Wire Wound 5W	3.3 $\Omega$	70012513
R3	Resistor - Wire Wound 5W	33 $\Omega$	70012512
R4	Resistor - Wire Wound 5W	33 $\Omega$	70012512
R5	Resistor - Wire Wound 5W	20 $\Omega$	70012514
R6	Resistor - Wire Wound 5W	3.3 $\Omega$	70012513



## AMPLIFIER FULL POWER OUTPUT VOLTAGES (PER CHANNEL)

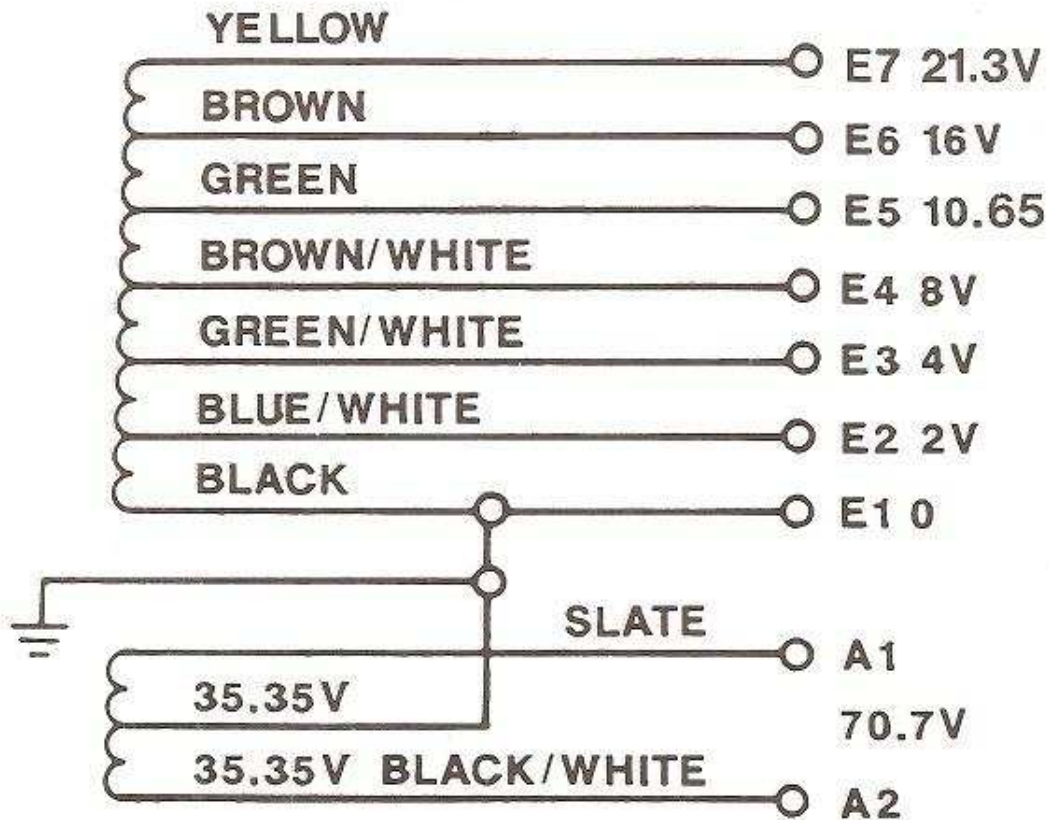
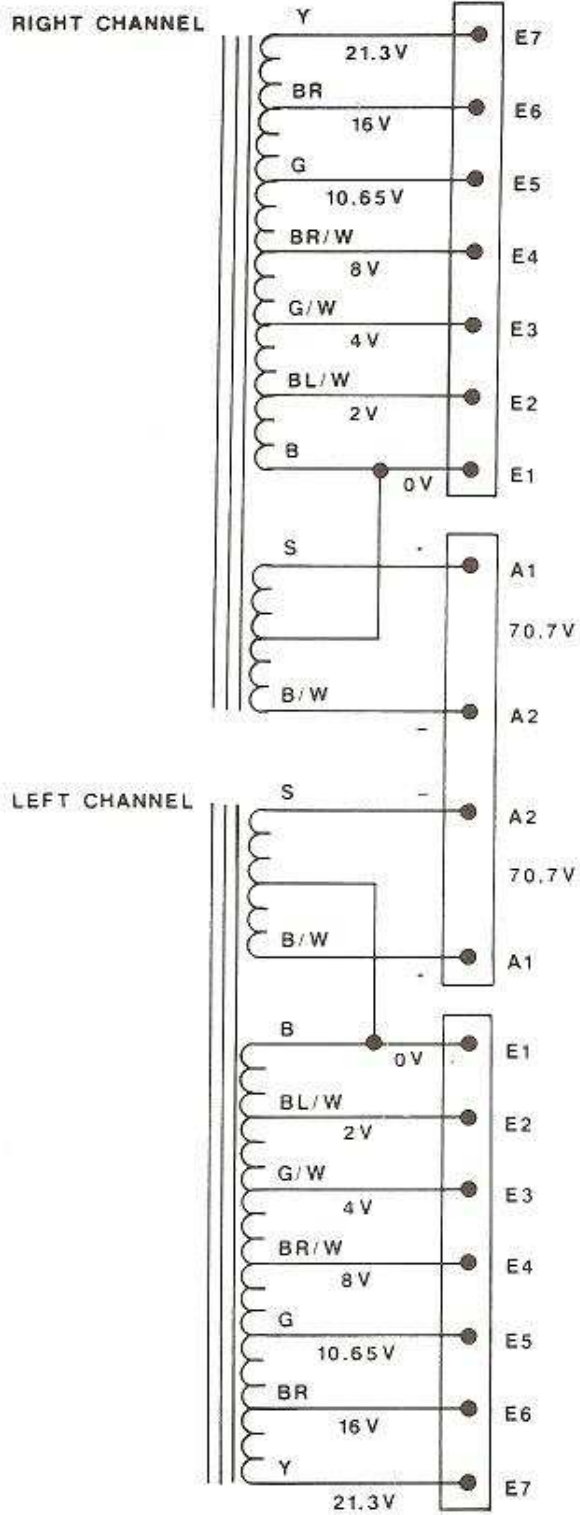
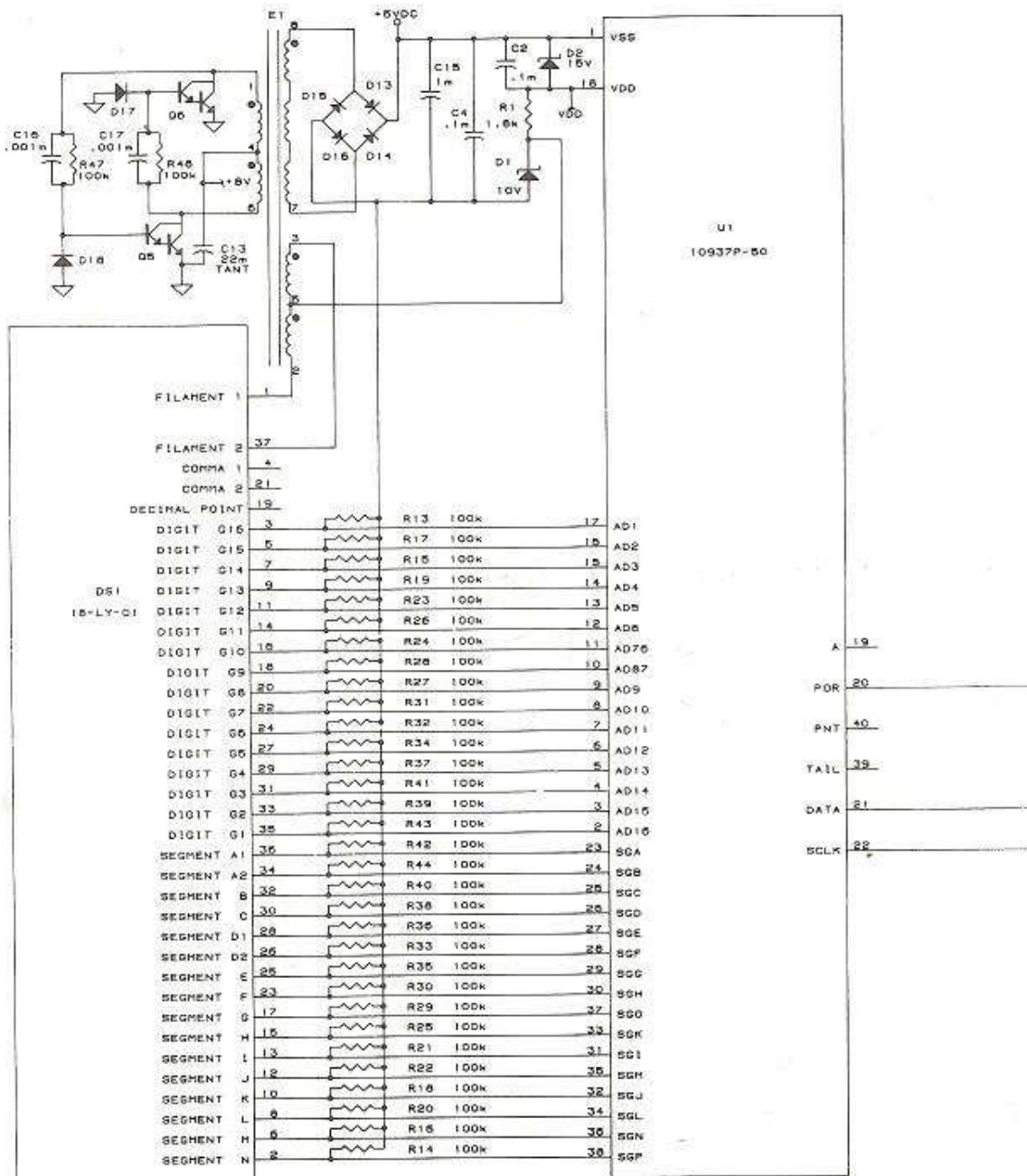

Figure 5-9. Transformer Output Voltages



For Equivalent Engineering Drawing See 40832101-Q2 A

Figure 5-10. Transformer Wiring Diagram





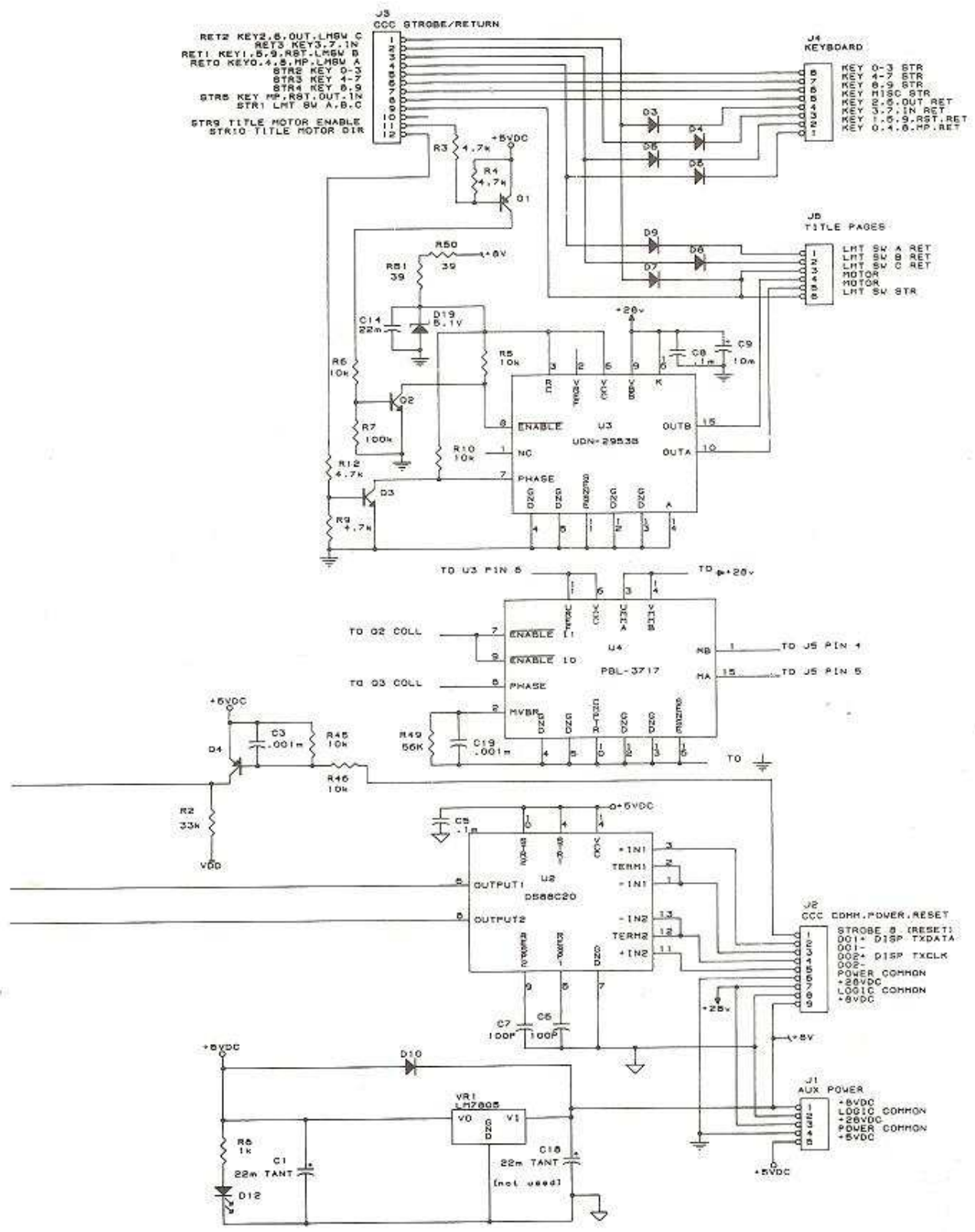

For Equivalent Engineering Drawing See 40632301-Q2 H

Figure 5-11. Display Assembly

## COMPONENT LIST FOR THE DISPLAY ASSEMBLY (40832301-H)

C1	Capacitor-Tantalum	22 Mf	70025104
C2	Capacitor-Monolithic Ceramic	.1 Mf	70028511
C3	Capacitor-Monolithic Ceramic	.001 Mf	70028518
C4	Capacitor-Monolithic Ceramic	.1 Mf	70028511
C5	Capacitor-Monolithic Ceramic	.1 Mf	70028511
C6	Capacitor-Monolithic Ceramic	100 Pf	70028601
C7	Capacitor-Monolithic Ceramic	100 Pf	70028601
C8	Capacitor-Monolithic Ceramic	.1 Mf	70028511
C9	Capacitor-Electrolytic	10 Mf	70023808
C13	Capacitor-Tantalum	22 Mf	70025104
C14	Capacitor-Tantalum	22 Mf	70025104
C15	Capacitor-Electrolytic	1 Mf	70028029
C16	Capacitor-Monolithic Ceramic	.001 Mf	70028518
C17	Capacitor-Monolithic Ceramic	.001 Mf	70028518
C18	NOT USED		
C19	Capacitor-Monolithic Ceramic	.001 Mf	70028518
D1	Diode-Zener	10 V	70035514
D2	Diode-Zener	15 V	70035522
D3-D10	Diode-Silicon		70035005
D11	NOT USED		
D12	LED-Block (90)		70035201
D13-D16	Diode-Silicon		70035005
D17	Diode-Silicon		70035012
D18	Diode-Silicon		70035012
D19	Diode - Zener	5.1 V	70035526
DS1	Display-VAC FLU (16 Character)		30933201
E1	Transformer, DC-DC/AC		30942101
J1	Wafer-Polarizing 90 (5 CKT)		70074405
J2	Wafer-Polarizing 90 (9 CKT)		70074409
J3	Wafer-Polarizing 90 (12 CKT)		70074412
J4	Wafer-Polarizing 90 (8 CKT)		70074408
J5	Wafer-Polarizing 90 (6 CKT)		70074406

Q1	Transistor-Silicon (PNP)	70030104
Q2	Transistor-Silicon (NPN)	70030008
Q3	Transistor-Silicon (NPN)	70030008
Q4	Transistor-Silicon (PNP)	70030104
Q5	Transistor-Darlington (NPN)	70030213
Q6	Transistor-Darlington (NPN)	70030213

Note: All resistors are 1/4 watt 5%, unless otherwise noted.

R1	Resistor-Carbon	1.8 K	79901182
R2	Resistor-Carbon	33 K	79901333
R3	Resistor-Carbon	4.7 K	79901472
R4	Resistor-Carbon	4.7 K	79901472
R5	Resistor-Carbon	10 K	79901103
R6	Resistor-Carbon	10 K	79901103
R7	Resistor-Carbon	100 K (1/8 W)	79905104
R8	Resistor-Carbon	1 K	79901102
R9	Resistor-Carbon	4.7 K	79901472
R10	Resistor-Carbon	10 K	79901103
R12	Resistor-Carbon	4.7 K	79901472
R13 Thru R44	Resistor-Carbon	100 K (1/8 W)	79905104
R45	Resistor-Carbon	10 K	79901103
R46	Resistor-Carbon	10 K	79901103
R47	Resistor-Carbon	100 K (1/8 W)	79905104
R48	Resistor-Carbon	100 K (1/8 W)	79905104
R49	Resistor-Carbon	56 K	79901563
R50	Resistor - Carbon	39 Ohm	79901390
R51	Resistor - Carbon	39 Ohm	79901390
U1	Driver-Display (VAC FLU) (10937)		30800237
U2	Receiver-Dual (RS-422)		30800228
U3	Driver-Motor (Full Bridge) (UDN-2953B)		30800229 <sup>1</sup>
U4	Driver-Motor (Full Bridge) (PBL-3717)		30800241 <sup>1</sup>
VR1	Regulator-Voltage (Linear IC)		70036506

<sup>1</sup> Use either 30800229 in the U3 position, or use 30800241 in the U4 position.



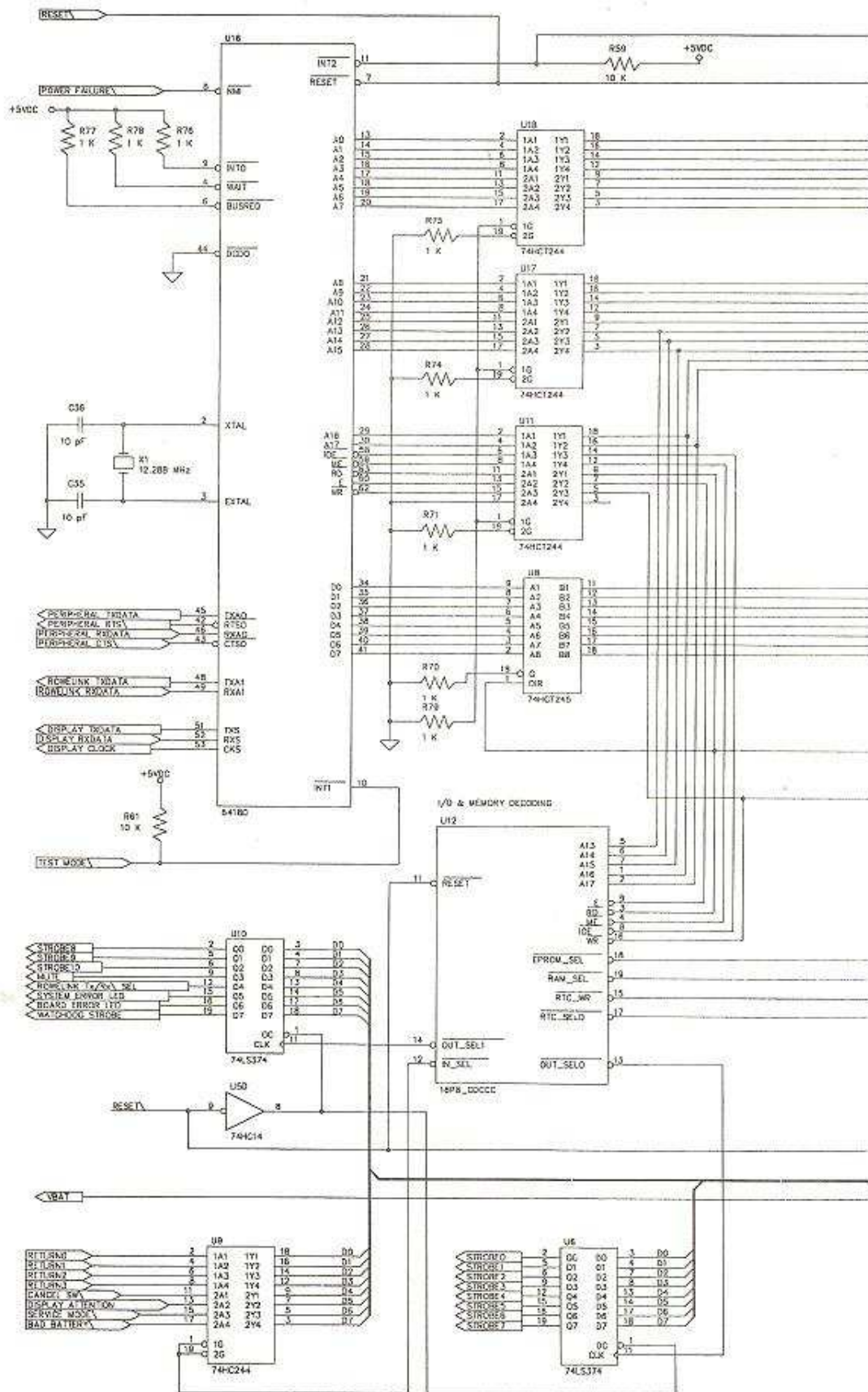

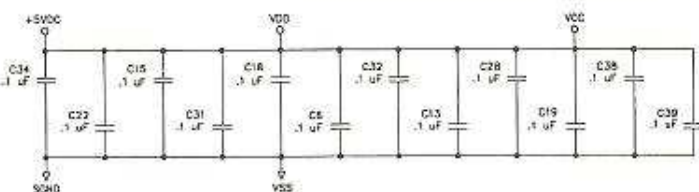
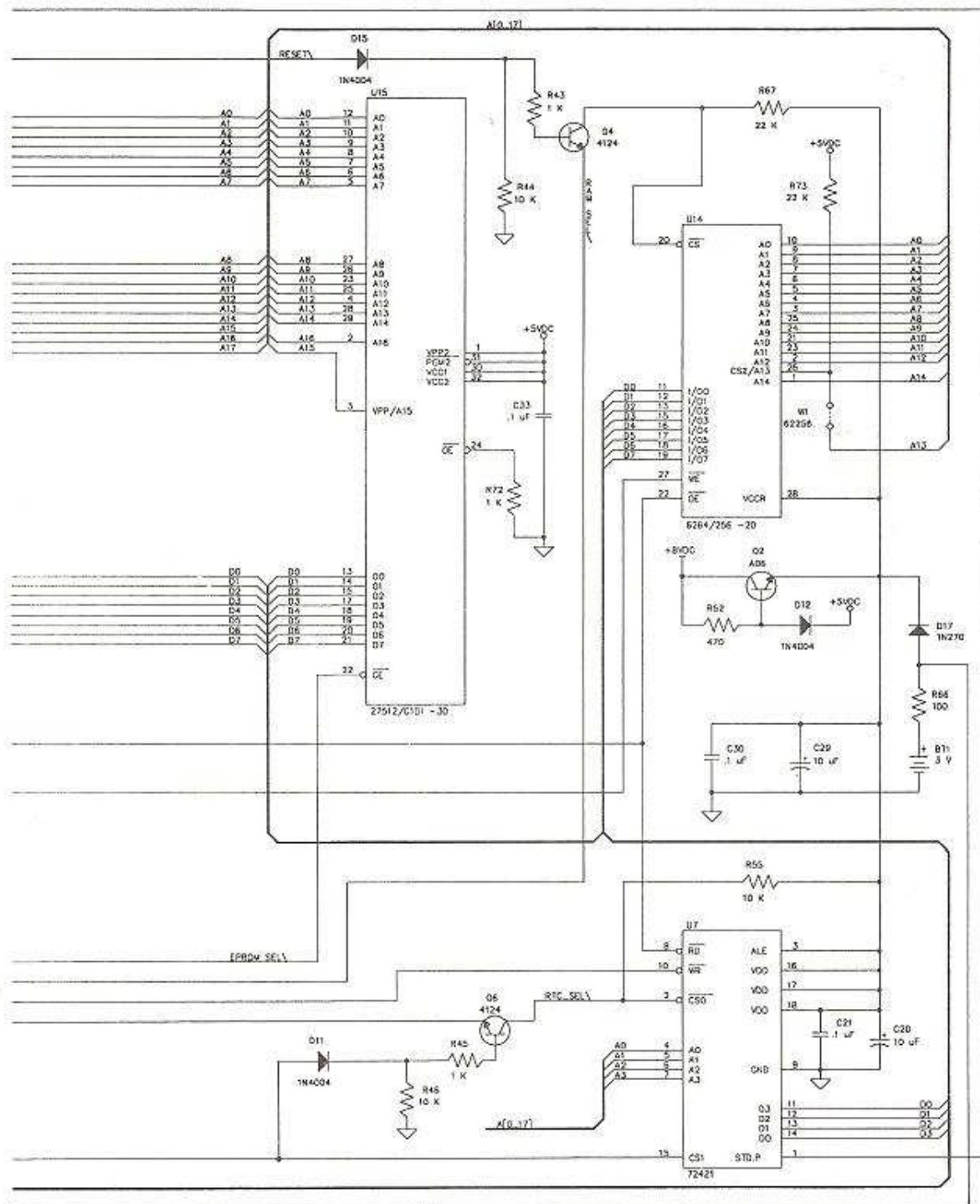

For Equivalent Engineering Drawing See 61031101-Q2 D

Figure 5-12A. Central Control Computer Schematic, Sheet 1

DISPLAY/KEYBOARD INTERFACE

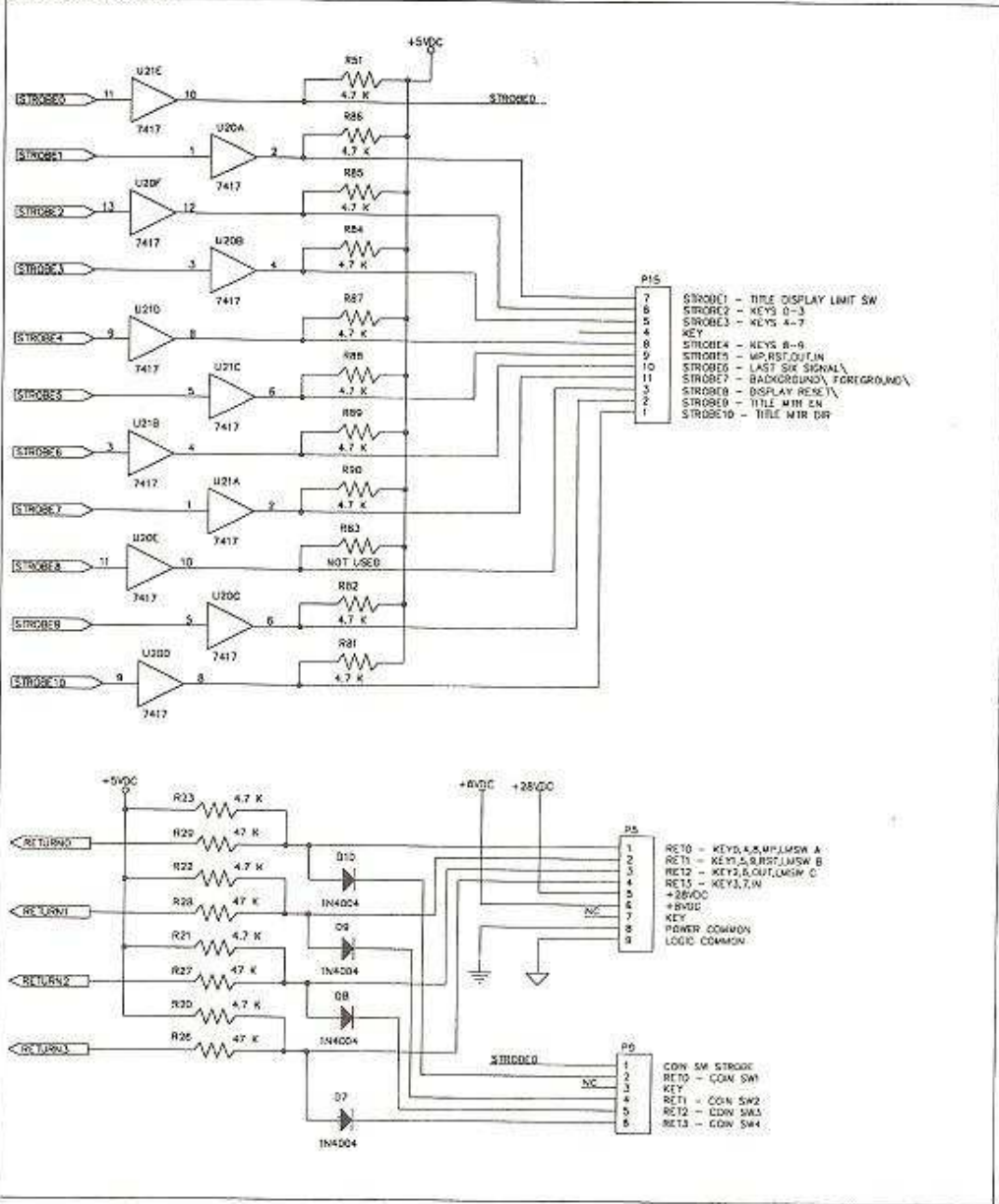

DISPLAY INTERFACE (DS422)

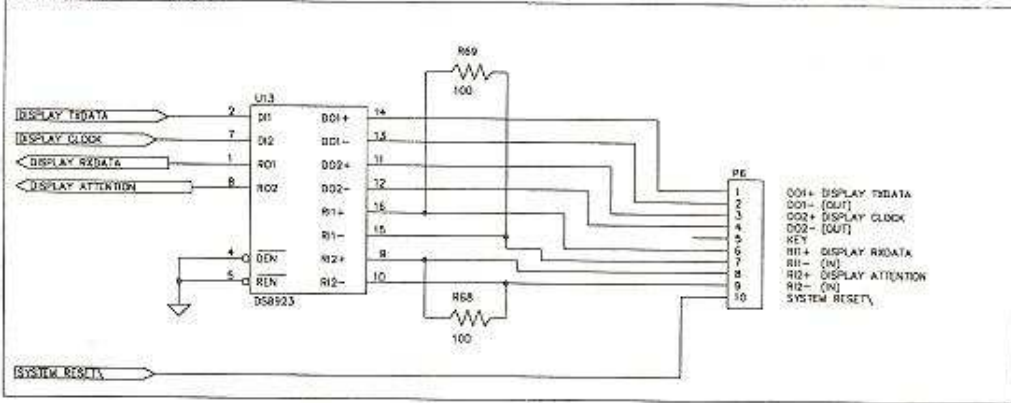



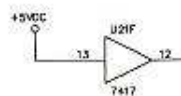
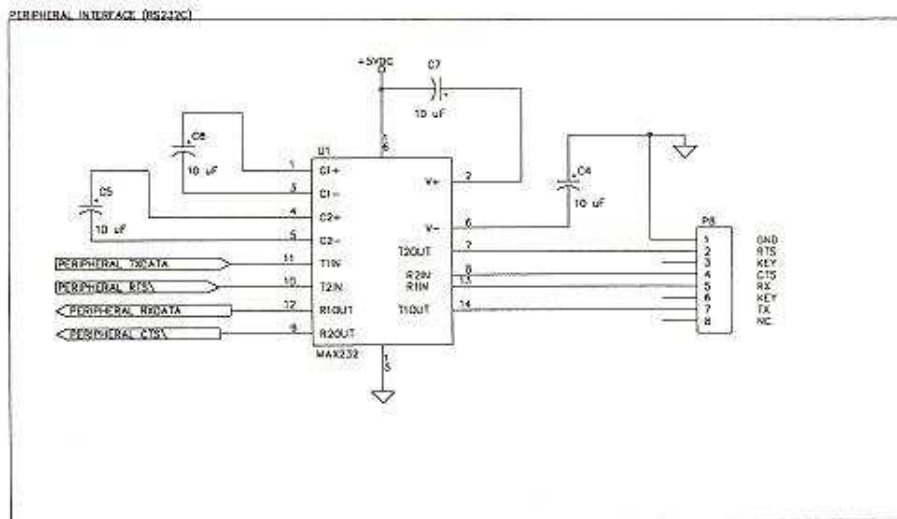
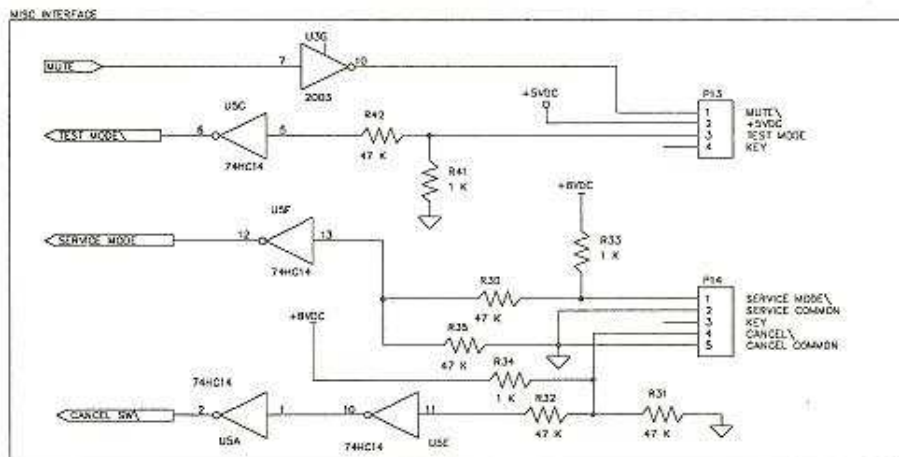
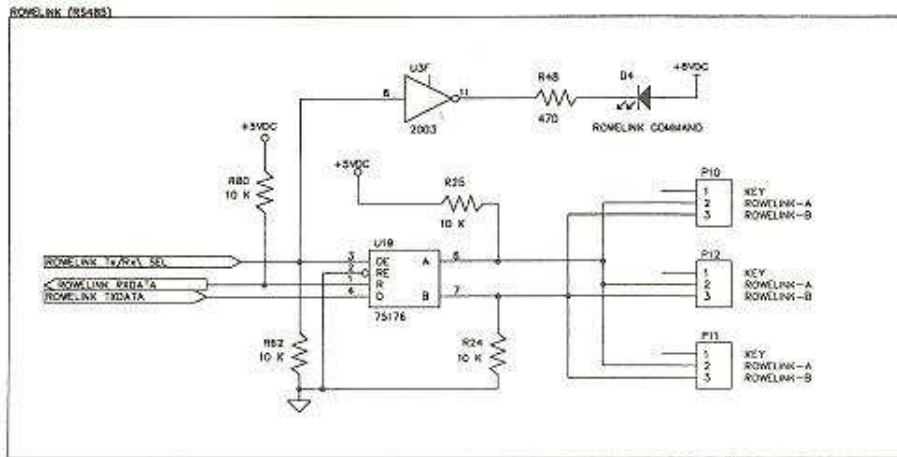

For Equivalent Engineering Drawing See 61031101-Q2 D

Figure 5-12A. Central Control Computer Schematic, Sheet 2

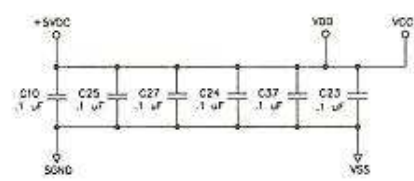
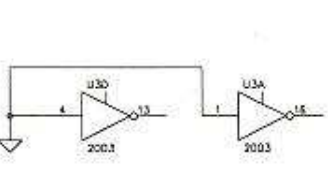
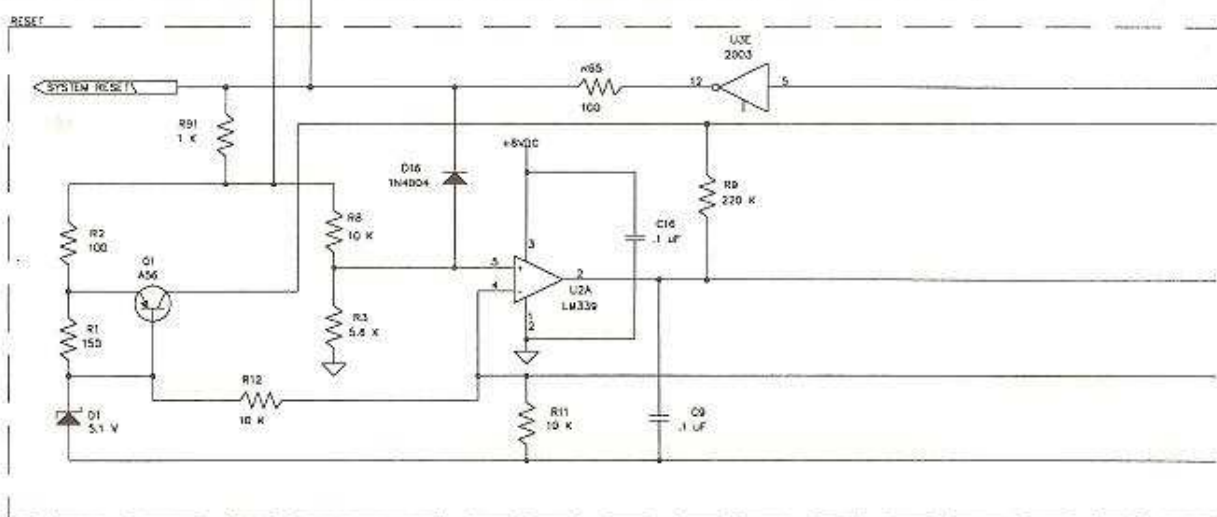
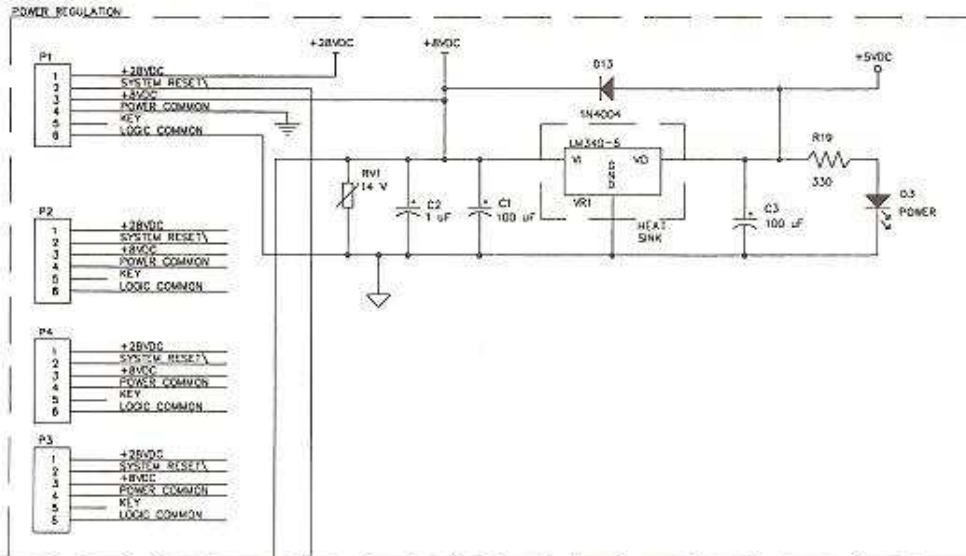
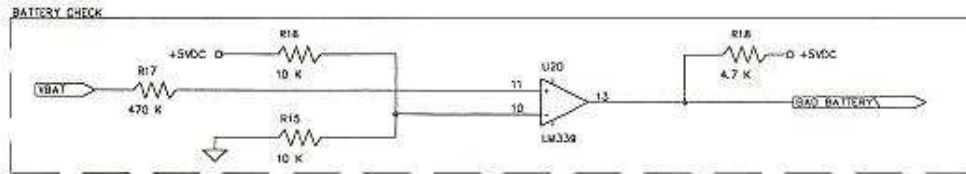
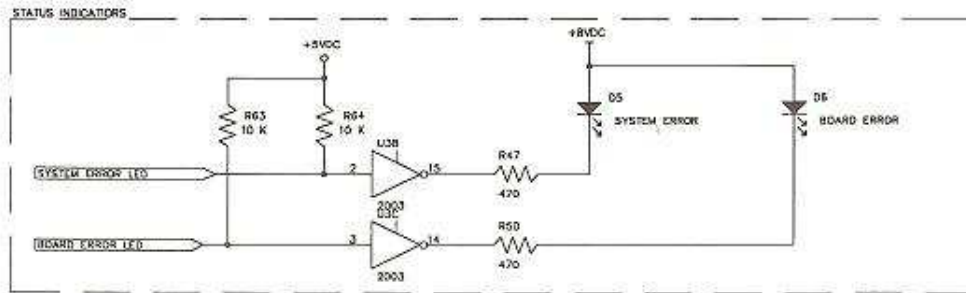

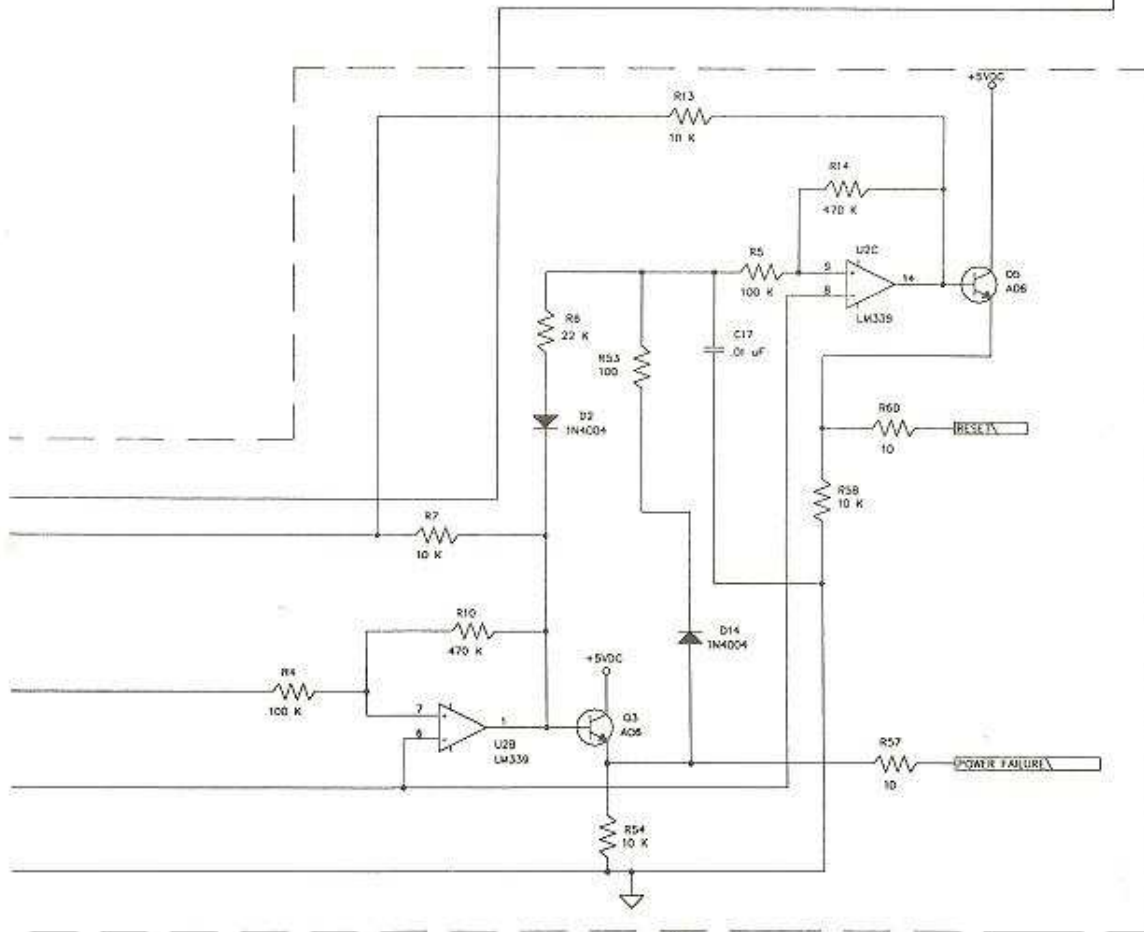
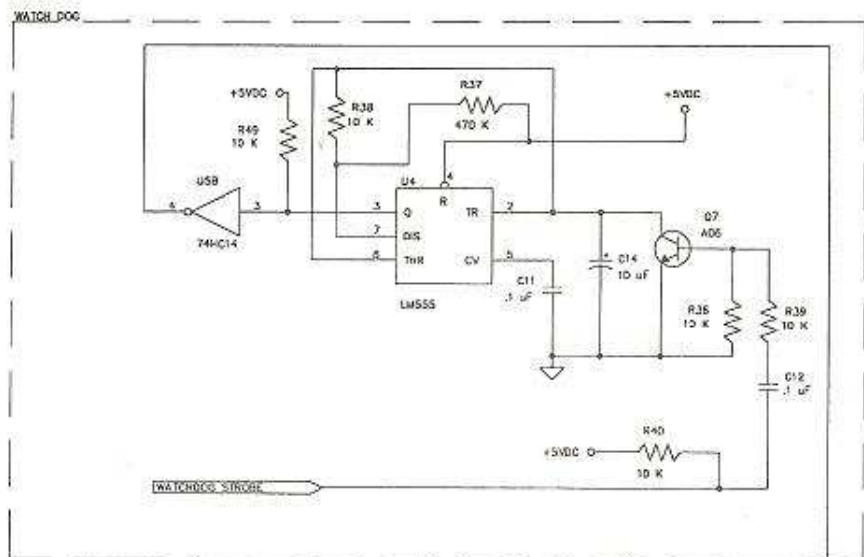

For Equivalent Engineering Drawing See 61031101-Q2 D

Figure 5-12A. Central Control Computer Schematic, Sheet 3



**CD-100A C.C.C IC Power And Common Pin Chart**

Ref.	Generic Part #	Power		Common	
		+5 VDC	+8 VDC	Logic	Power
U1	MAX232	16	—	15	—
U2	LM339	—	3	12	—
U3	2003	—	—	8	—
U4	LM555	8	—	1	—
U5	74HC14	14	—	7	—
U6	74LS374	20	—	10	—
U7	72421	16,17,18	—	9	—
U8	74HCT245	20	—	10	—
U9	74HC244	20	—	10	—
U10	74LS374	20	—	10	—
U11	74HCT244	20	—	10	—
U12	18P8_CDCCC	20	—	10	—
U13	DS8923	3	—	6	—
U14	6264/6256	28	—	14	—
U15	27512/27C101	32,30	—	16	—
U16	64180	32	—	1,33	—
U17	74HCT244	20	—	10	—
U18	74HCT244	20	—	10	—
U19	75176	8	—	5	—
U20	7417	14	—	7	—
U21	7417	14	—	7	—

For Equivalent Engineering Drawing See 61031101-Q2 D

**Figure 5-12A. Central Control Computer Schematic, Sheet 4**

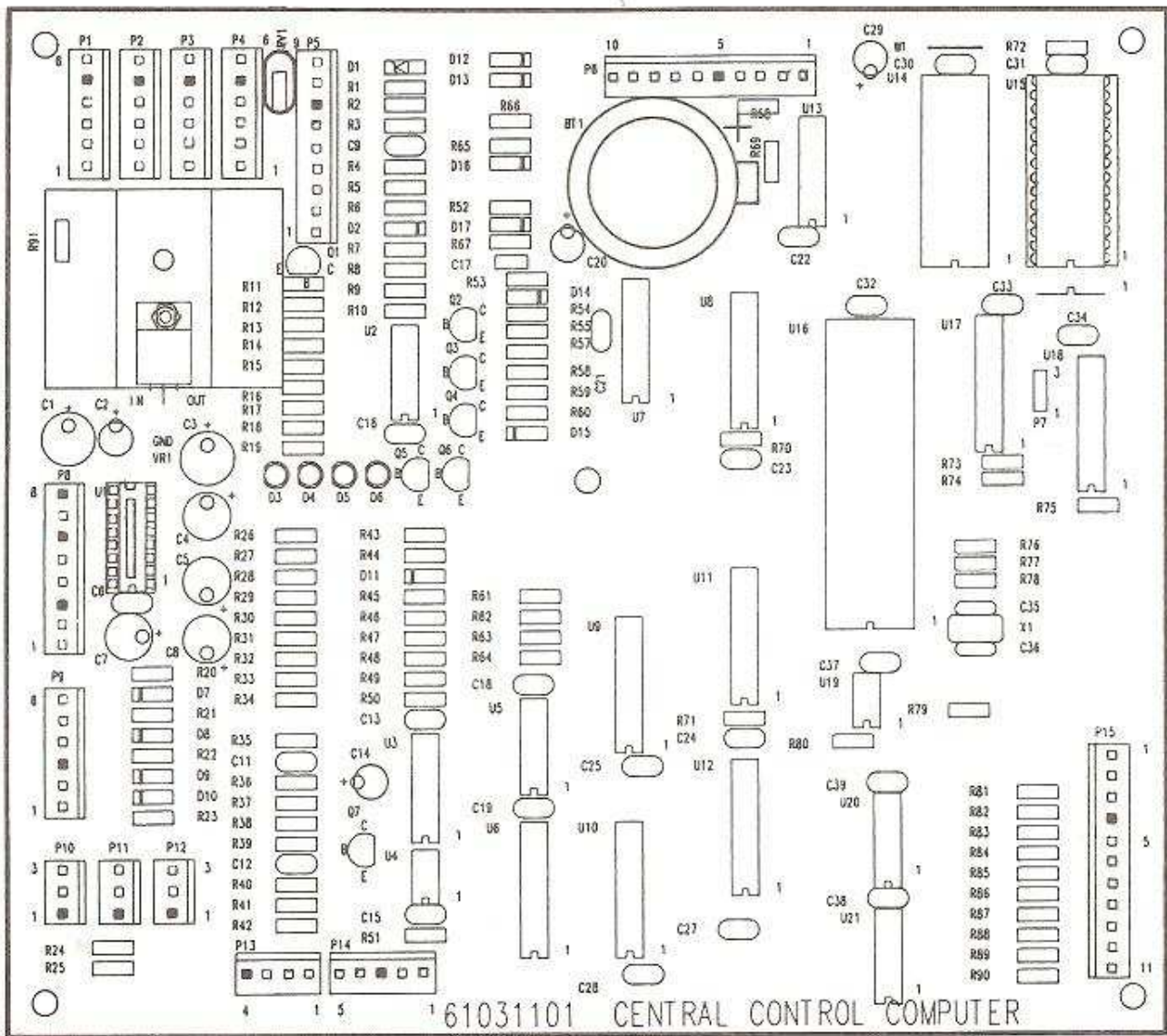

Figure 5-12B. Central Control Computer Circuit Board Layout



# COMPONENT LIST FOR CENTRAL CONTROL COMPUTER (61031101-J)

BT1	Battery - Lithium	750 mah 3V OR 160 mah 3V	40788901 30873101
C1	Capacitor - Electrolytic	100 mf	70023814
C2	Capacitor - Tantalum	1 mf	70025121
C3	Capacitor - Electrolytic	100 mf	70023814
C4	Capacitor - Electrolytic	10 mf	70023808
C5	Capacitor - Electrolytic	10 mf	70023808
C6	Capacitor - Monolithic Ceramic	.1 mf	70028511
C7	Capacitor - Electrolytic	10 mf	70023808
C8	Capacitor - Electrolytic	10 mf	70023808
C9	Capacitor - Monolithic Ceramic	.1 mf	70028511
C10	Capacitor - Monolithic Ceramic	.1 mf	70028511
C11	Capacitor - Monolithic Ceramic	.1 mf	70028511
C12	Capacitor - Monolithic Ceramic	.1 mf	70028511
C13	Capacitor - Monolithic Ceramic	.1 mf	70028511
C14	Capacitor - Electrolytic	10 mf	70023808
C15	Capacitor - Monolithic Ceramic	.1 mf	70028511
C16	Capacitor - Monolithic Ceramic	.1 mf	70028511
C17	Capacitor - Monolithic Ceramic	.01 mf	70028502
C18	Capacitor - Monolithic Ceramic	.1 mf	70028511
C19	Capacitor - Monolithic Ceramic	.1 mf	70028511
C20	Capacitor - Electrolytic	10 mf	70023808
C21	Capacitor - Monolithic Ceramic	.1 mf	70028511
C22	Capacitor - Monolithic Ceramic	.1 mf	70028511
C23	Capacitor - Monolithic Ceramic	.1 mf	70028511
C24	Capacitor - Monolithic Ceramic	.1 mf	70028511
C25	Capacitor - Monolithic Ceramic	.1 mf	70028511
C27	Capacitor - Monolithic Ceramic	.1 mf	70028511
C28	Capacitor - Monolithic Ceramic	.1 mf	70028511
C29	Capacitor - Electrolytic	10 mf	70023808
C30	Capacitor - Monolithic Ceramic	.1 mf	70028511
C31	Capacitor - Monolithic Ceramic	.1 mf	70028511
C32	Capacitor - Monolithic Ceramic	.1 mf	70028511
C33	Capacitor - Monolithic Ceramic	.1 mf	70028511
C34	Capacitor - Monolithic Ceramic	.1 mf	70028511
C35	Capacitor - Monolithic Ceramic	10 pf	70028701
C36	Capacitor - Monolithic Ceramic	10 pf	70028701
C37	Capacitor - Monolithic Ceramic	.1 mf	70028511
C38	Capacitor - Monolithic Ceramic	.1 mf	70028511
C39	Capacitor - Monolithic Ceramic	.1 mf	70028511
D1	Diode - Zener (5.1 V)		70035526
D2	Diode - Silicon	IN4004	70035005
D3	Diode - Light Emitting		70035305
D4	Diode - Light Emitting		70035305
D5	Diode - Light Emitting		70035305
D6	Diode - Light Emitting		70035305
D7	Diode - Silicon	IN4004	70035005
D8	Diode - Silicon	IN4004	70035005
D9	Diode - Silicon	IN4004	70035005
D10	Diode - Silicon	IN4004	70035005
D11	Diode - Silicon	IN4004	70035005
D12	Diode - Silicon	IN4004	70035005
D13	Diode - Silicon	IN4004	70035005
D14	Diode - Silicon	IN4004	70035005
D15	Diode - Silicon	IN4004	70035005
D16	Diode - Silicon	IN4004	70035005
D17	Diode - Germanium	IN270	70035101



P1	Wafer - Polarizing	6 CKT	70075006
P2	Wafer - Polarizing	6 CKT	70075006
P3	Wafer - Polarizing	6 CKT	70075006
P4	Wafer - Polarizing	6 CKT	70075006
P5	Wafer - Polarizing	9 CKT	70075009
P6	Wafer - Polarizing	10 CKT	70075010
P7	NOT USED		
P8	Wafer - Polarizing	8 CKT	70075008
P9	Wafer - Polarizing	6 CKT	70075006
P10	Wafer - Polarizing	3 CKT	70075003
P11	Wafer - Polarizing	3 CKT	70075003
P12	Wafer - Polarizing	3 CKT	70075003
P13	Wafer - Polarizing	4 CKT	70075004
P14	Wafer - Polarizing	5 CKT	70075005
P15	Wafer - Polarizing	11 CKT	70075011

Q1	Transistor - Silicon (PNP)		70030104
Q2	Transistor - Silicon (NPN)		70030008
Q3	Transistor - Silicon (NPN)		70030008
Q4	Transistor - Silicon (NPN)		70031301
Q5	Transistor - Silicon (NPN)		70030008
Q6	Transistor - Silicon (NPN)		70031301
Q7	Transistor - Silicon (NPN)		70030008

**Note:** All resistors are 1/4 watt 5%, unless otherwise noted.

R1	Resistor - Carbon	150 Ohm	79901151
R2	Resistor - Carbon	100 Ohm	79901101
R3	Resistor - Carbon	5.6 K (1/4 W, 2%)	79902562
R4	Resistor - Carbon	100 K	79901104
R5	Resistor - Carbon	100 K	79901104
R6	Resistor - Carbon	22 K	79901223
R7	Resistor - Carbon	10 K	79901103
R8	Resistor - Carbon Film	10 K (1/4 W, 2%)	79902103
R9	Resistor - Carbon	220 K	79901224
R10	Resistor - Carbon	470 K	79901474
R11	Resistor - Carbon Film	10 K (1/4 W, 2%)	79902103
R12	Resistor - Carbon Film	10 K (1/4 W, 2%)	79902103
R13	Resistor - Carbon	10 K	79901103
R14	Resistor - Carbon	470 K	79901474
R15	Resistor - Carbon	10 K	79901103
R16	Resistor - Carbon	10 K	79901103
R17	Resistor - Carbon	470 K	79901474
R18	Resistor - Carbon	4.7 K	79901472
R19	Resistor - Carbon	330 Ohm	79901331
R20	Resistor - Carbon	4.7 K	79901472
R21	Resistor - Carbon	4.7 K	79901472
R22	Resistor - Carbon	4.7 K	79901472
R23	Resistor - Carbon	4.7 K	79901472
R24	Resistor - Carbon	10 K	79901103

COMPONENT LIST FOR CENTRAL CONTROL COMPUTER (61031101)

(Continued)

R25	Resistor - Carbon	10 K	79901103
R26	Resistor - Carbon	47 K	79901473
R27	Resistor - Carbon	47 K	79901473
R28	Resistor - Carbon	47 K	79901473
R29	Resistor - Carbon	47 K	79901473
R30	Resistor - Carbon	47 K	79901473
R31	Resistor - Carbon	47 K	79901473
R32	Resistor - Carbon	47 K	79901473
R33	Resistor - Carbon	1 K	79901102
R34	Resistor - Carbon	1 K	79901102
R35	Resistor - Carbon	47 K	79901473
R36	Resistor - Carbon	10 K	79901103
R37	Resistor - Carbon	470 K	79901474
R38	Resistor - Carbon	10 K	79901103
R39	Resistor - Carbon	10 K	79901103
R40	Resistor - Carbon	10 K	79901103
R41	Resistor - Carbon	1 K	79901102
R42	Resistor - Carbon	47 K	79901473
R43	Resistor - Carbon	1 K	79901102
R44	Resistor - Carbon	10 K	79901103
R45	Resistor - Carbon	1 K	79901102
R46	Resistor - Carbon	10 K	79901103
R47	Resistor - Carbon	470 Ohm	79901471
R48	Resistor - Carbon	470 Ohm	79901471
R49	Resistor - Carbon	10 K	79901103
R50	Resistor - Carbon	470 Ohm	79901471
R51	Resistor - Carbon	4.7 K	79901472
R52	Resistor - Carbon	470 Ohm	79901471
R53	Resistor - Carbon	100 Ohm	79901101
R54	Resistor - Carbon	10 K	79901103
R55	Resistor - Carbon	10 K	79901103
R57	Resistor - Carbon	10 Ohm	79901100
R58	Resistor - Carbon	10 K	79901103
R59	Resistor - Carbon	10 K	79901103
R60	Resistor - Carbon	10 Ohm	79901100
R61	Resistor - Carbon	10 K	79901103
R62	Resistor - Carbon	10 K	79901103
R63	Resistor - Carbon	10 K	79901103
R64	Resistor - Carbon	10 K	79901103
R65	Resistor - Carbon	100 Ohm	79901101
R66	Resistor - Carbon	100 Ohm	79901101
R67	Resistor - Carbon	22 K	79901223
R68	Resistor - Carbon	100 Ohm	79901101
R69	Resistor - Carbon	100 Ohm	79901101
R70	Resistor - Carbon	1 K	79901102
R71	Resistor - Carbon	1 K	79901102
R72	Resistor - Carbon	1 K	79901102
R73	Resistor - Carbon	22 K	79901223
R74	Resistor - Carbon	1 K	79901102
R75	Resistor - Carbon	1 K	79901102
R76	Resistor - Carbon	1 K	79901102



R77	Resistor - Carbon	1 K	79901102
R78	Resistor - Carbon	1 K	79901102
R79	Resistor - Carbon	1 K	79901102
R80	Resistor - Carbon	10 K	79901103
R81	Resistor - Carbon	4.7 K	79901472
R82	Resistor - Carbon	4.7 K	79901472
R83	NOT USED		
R84	Resistor - Carbon	4.7 K	79901472
R85	Resistor - Carbon	4.7 K	79901472
R86	Resistor - Carbon	4.7 K	79901472
R87	Resistor - Carbon	4.7 K	79901472
R88	Resistor - Carbon	4.7 K	79901472
R89	Resistor - Carbon	4.7 K	79901472
R90	Resistor - Carbon	4.7 K	79901472
R91	Resistor - Carbon	1 K	79901102
RV1	Metal Oxide Varistor	11 V (OR 14V)	OR 70037505 70037507
U1	NOT USED		
U2	I.C. - Quad Comparator (LM339)	(3302)	70036801
U3	I.C. - Darlington Array	(2003)	70036901
U4	I.C. - Timer	(LM555)	70033801
U5	I.C. - HCT (Hex Schmitt Trigger)	74HC14	79940014
U6	I.C. - Octal Edge Triggered F/F	74LS374	70037111
U7	I.C. - Calendar Clock	72421	30800236
U8	I.C. - HCT (Octal Bus Transceiver)	74HCT245	79930245
U9	I.C. - HC-Tristate Octal Buffer	74HC244	79940244
U10	I.C. - Octal Edge Triggered F/F	74LS374	70037111
U11	I.C. - HCT (Octal Buffer/Line Driver)	74HCT244	79930244
U12	I.C. - PAL 18P8-CDCCC		30800232
U13	I.C. - RS-422 Dual Driver/Rcvr	DS8923	30800230
U14	I.C. - CMOS RAM 8K X 8	6264	70036604
U15	I.C. - 64K X 8 EPROM	27512	70039903
U16	I.C. - Microprocessor	64180	70039126
U17	I.C. - HCT (Octal Buffer/Line DRIVER)	74HCT244	79930244
U18	I.C. - HCT (octal Buffer/Line Driver)	74HCT244	79930244
U19	I.C. - Transceiver (RS-485)	75176	70037801
U20	I.C. - TTL Buffer (Open Collector)	7417	70036305
U21	I.C. - TTL Buffer (Open Collector)	7417	70036305
VR1	Regulator - Voltage (Linear I.C.)	LM340-5	70036505
W1	Not Used		
X1	Crystal - Quartz (12.288 Mhz)		25167314



The chart below shows the various combinations of strobes (outputs from the CCC) and returns (inputs to the CCC) and their corresponding functions.

Strobes 0 through 5 appear on Returns 0 through 3 when the indicated switches are activated.

**For Example:** If you need to be sure that Key 5 is working, find Key 5 in table 5-3. This matrix entry indicates that, when Strobe 3 is active and Key 5 is pressed, Return 1 becomes active.

Not all of the strobes and returns operate in this matrix mode; Returns 4 through 7 and Strobes 7 through 15 have unique functions, which are listed in the table.

Table 5-3. CD-100A CCC I/O Matrix

		INPUTS							
		RETURNS				DEDICATED			
		0	1	2	3	4	5	6	7
<b>STROBES</b>	0	5¢ Coin Switch	10¢ Coin Switch	25¢ Coin Switch	50¢ Coin Switch	C A N C E L  S W I T C H	D I S P L Y  A T T E N T I O N	S E R V I C E  S W I T C H	L O W  B A T T E R Y  D E T
	1	Title Disp Limit	Title Disp Index	Reserved	UK Defaults				
	2	Key 0	Key 1	Key 2	Key 3				
	3	Key 4	Key 5	Key 6	Key 7				
	4	Key 8	Key 9		Audit Report Start Button				
	5	POPULAR	RESET	OUT	IN				
<b>DEDICATED</b>	6	Not Used							
	7	Background Music Active							
	8	Display Reset - Controls hardware reset on the display driver chip							
	9	Sends speed info to motor chip							
	10	Sends direction info to motor chip							
	11	Mute							
	12	ROWELINK Tx/Rx Select							
	13	SYSTEM ERROR LED							
	14	BOARD ERROR LED							
	15	Watchdog Strobe							

This page intentionally left blank.

# MECHANISM MODULE

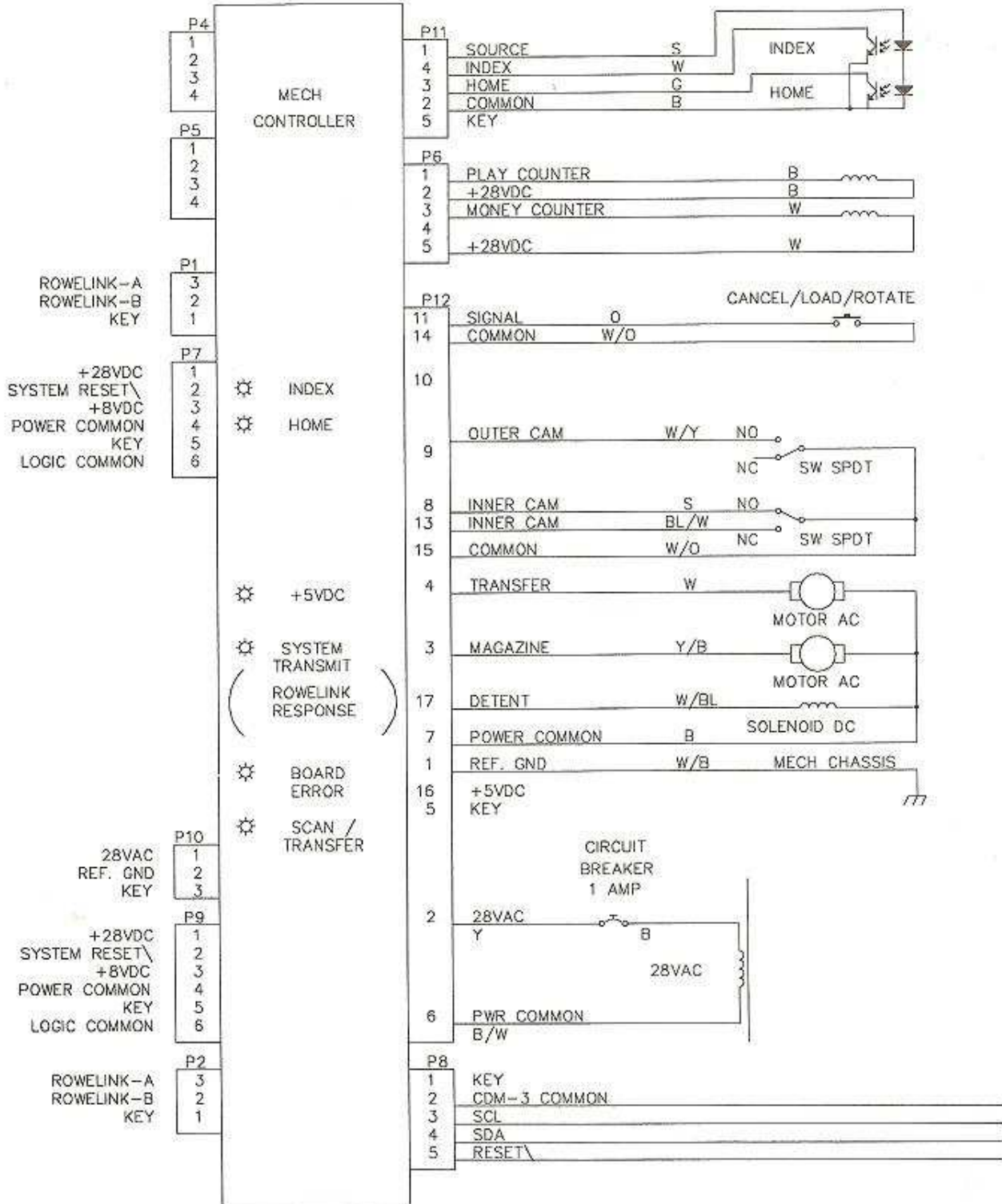



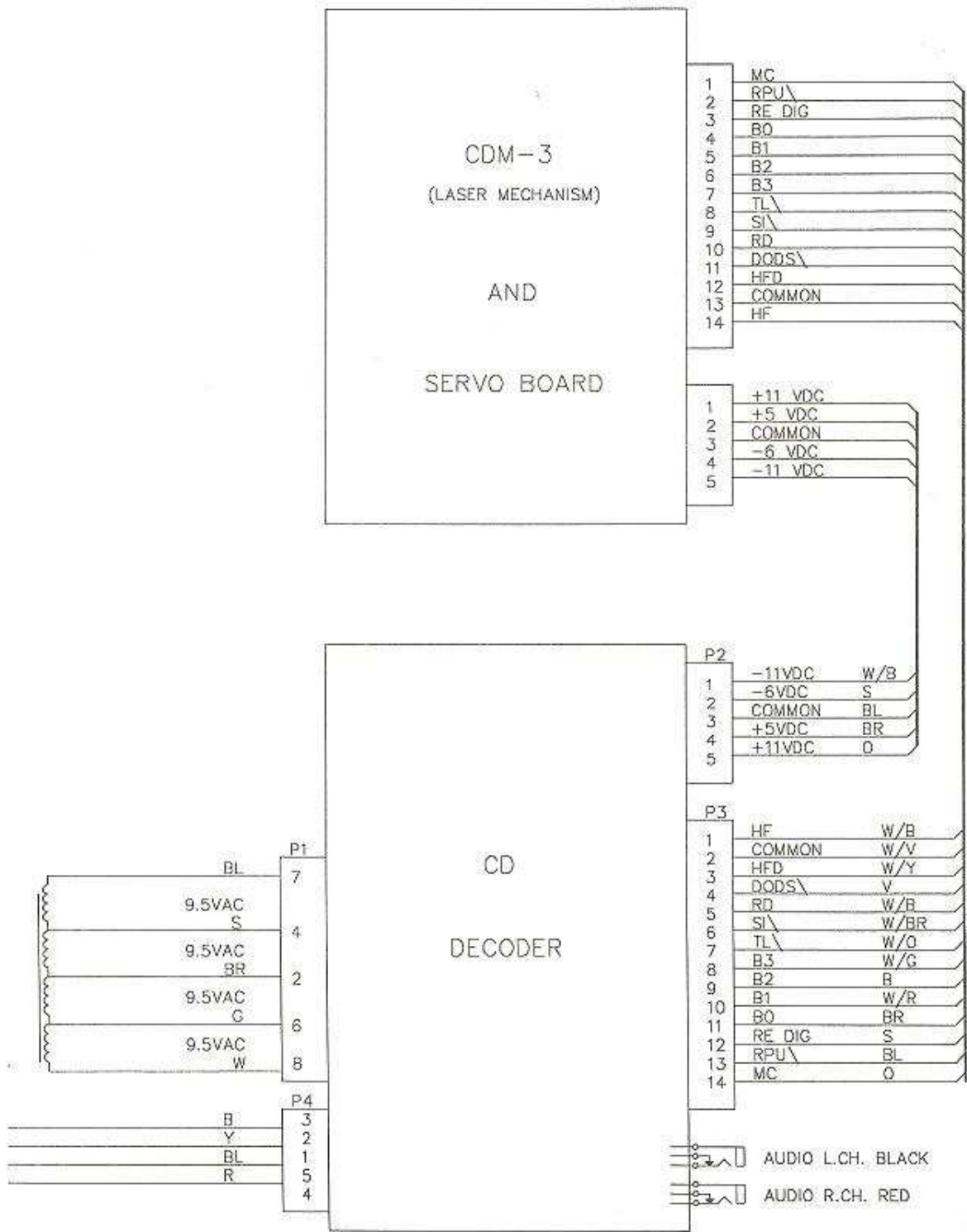
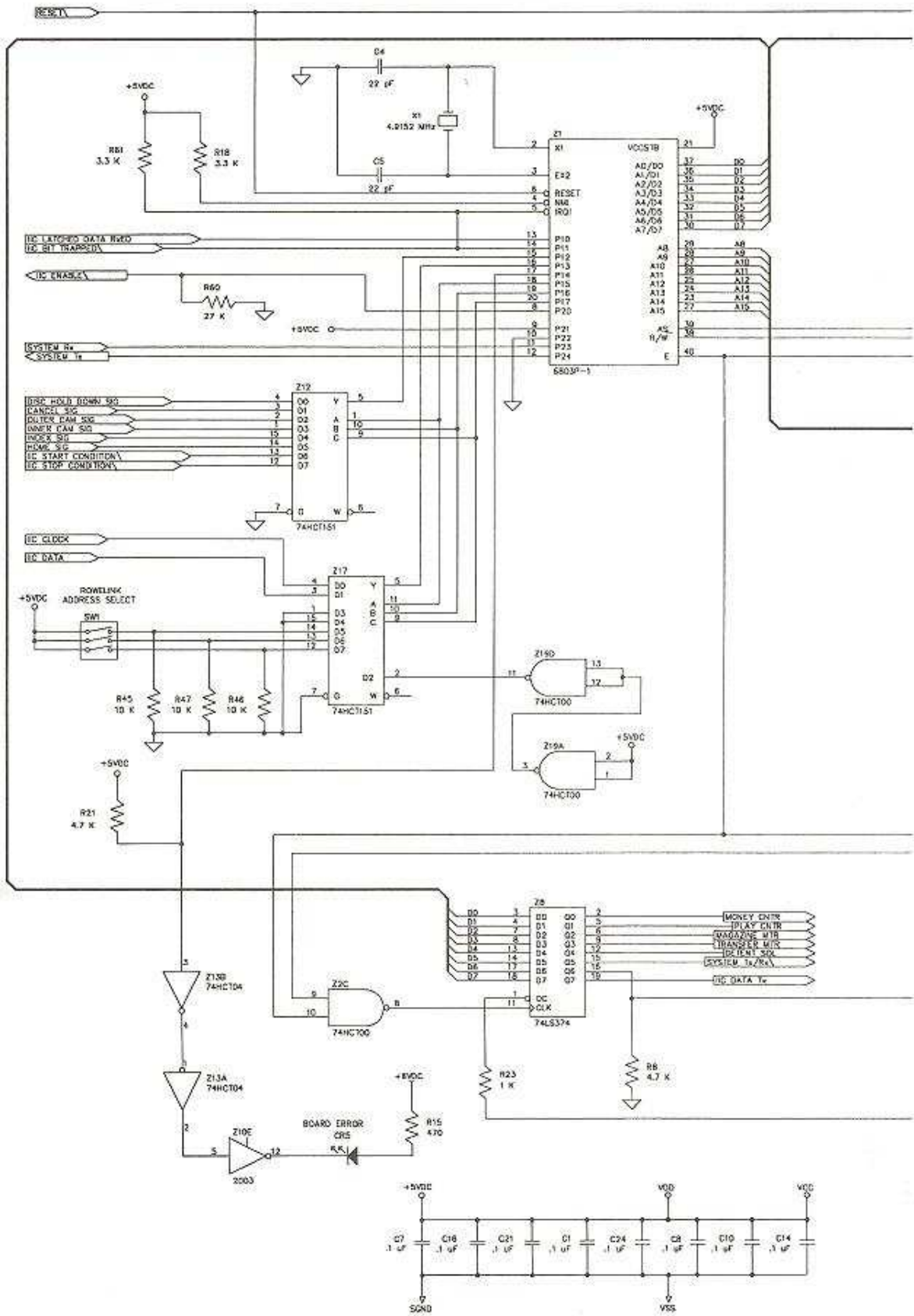
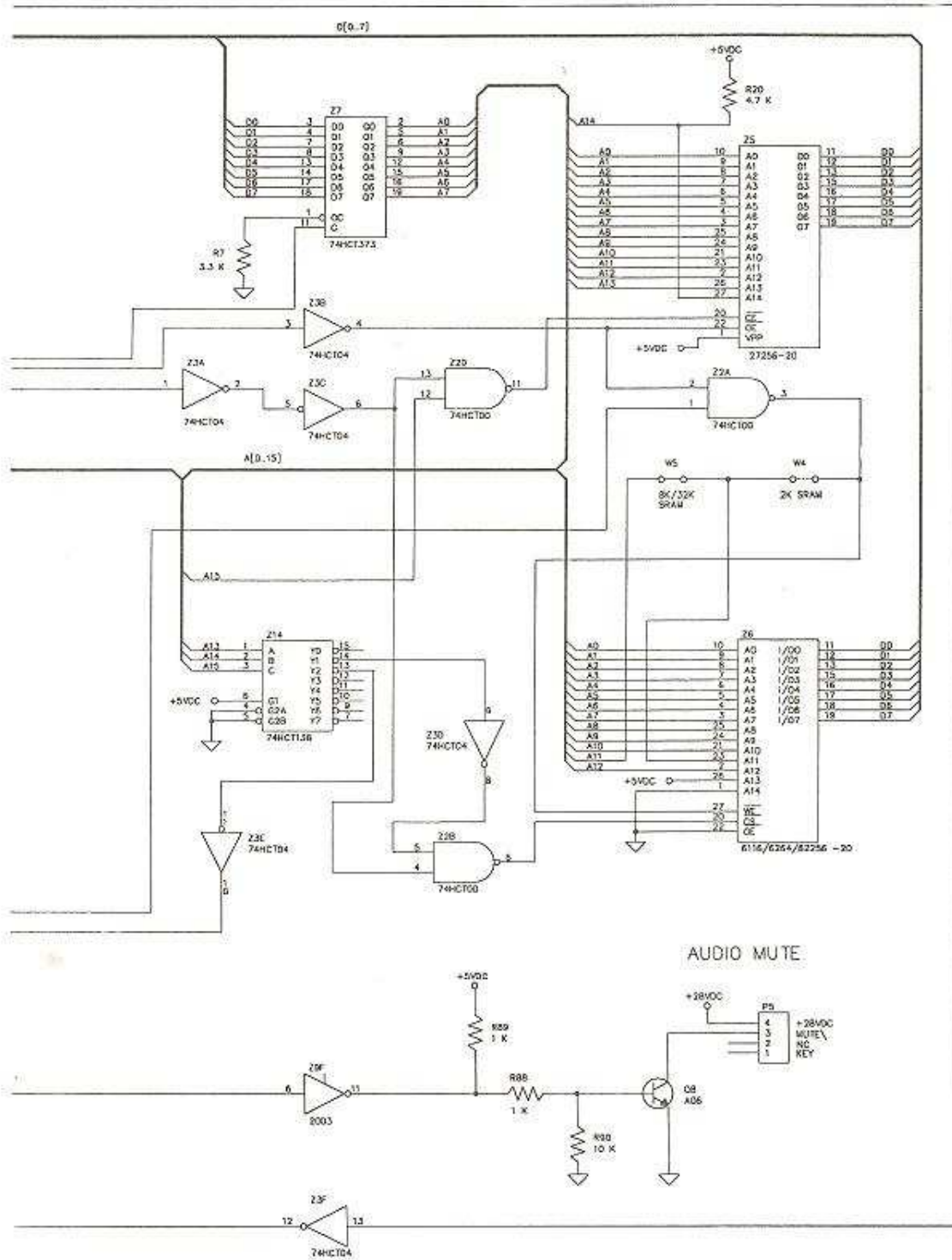

Figure 5-13A. Mechanism Control Assembly Block Diagram





For Equivalent Engineering Drawing See 61030603-Q2 A

Figure 5-13B. Mechanism Control Assembly Schematic, Sheet 1



SERVO I/P COMMUNICATION

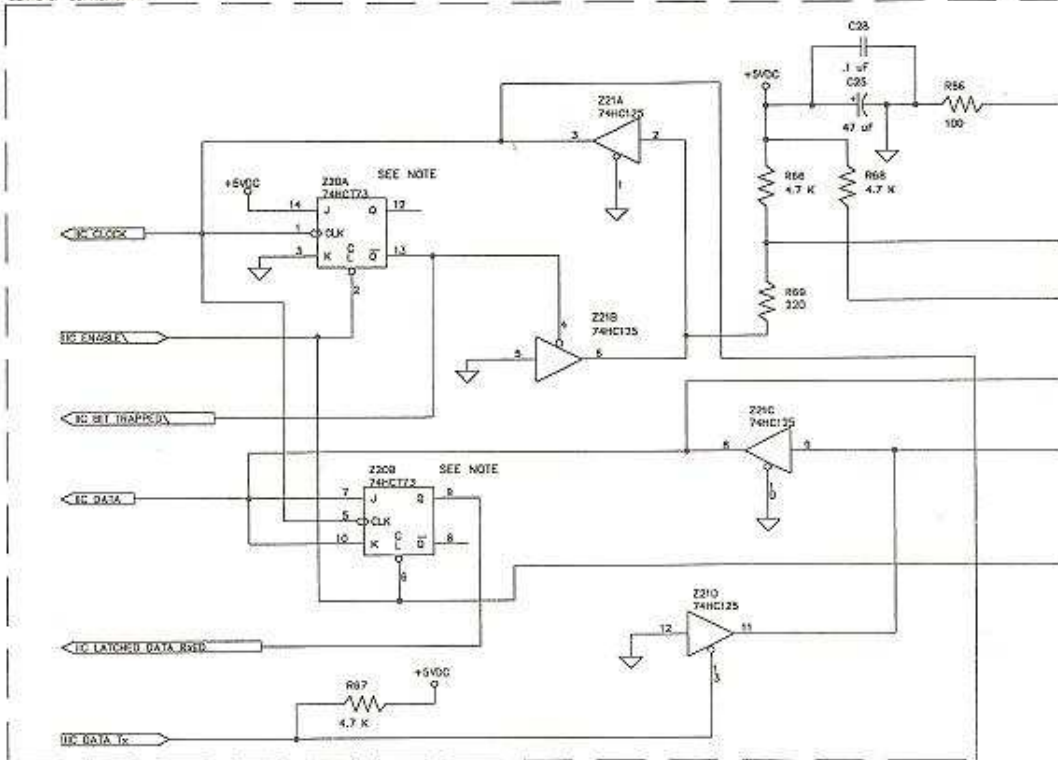

VOLTAGE REGULATION

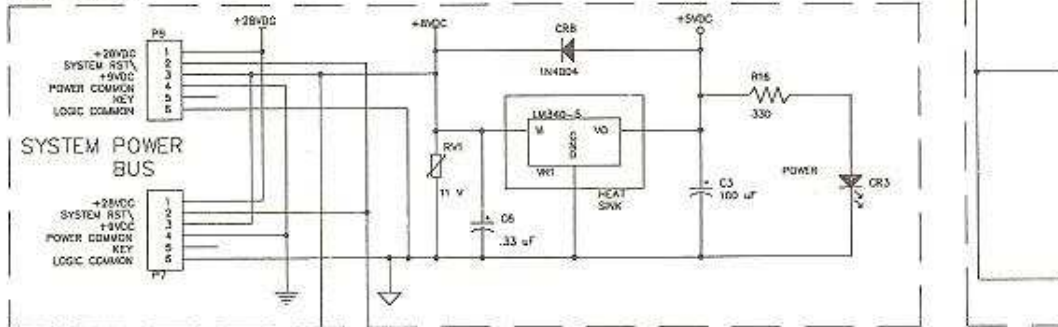

RESET CIRCUIT

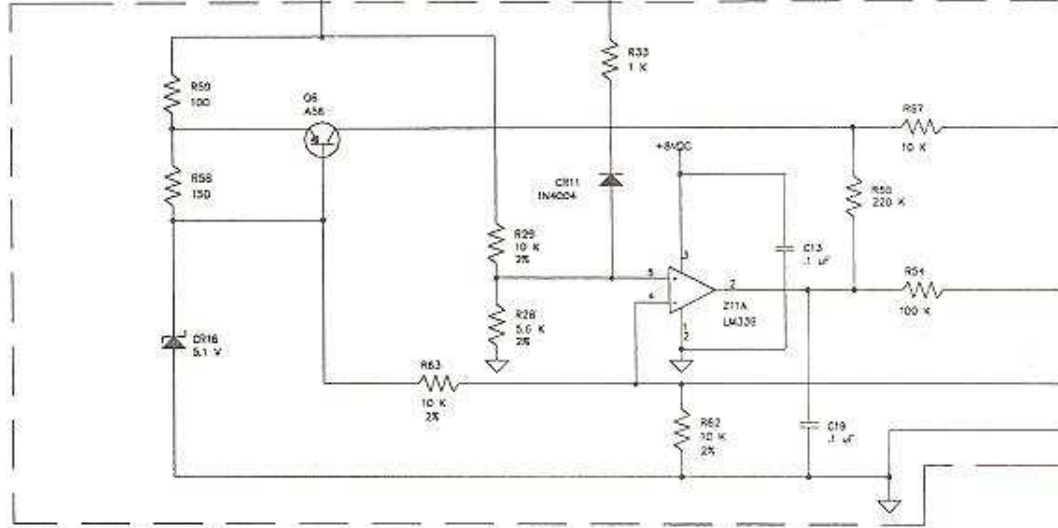

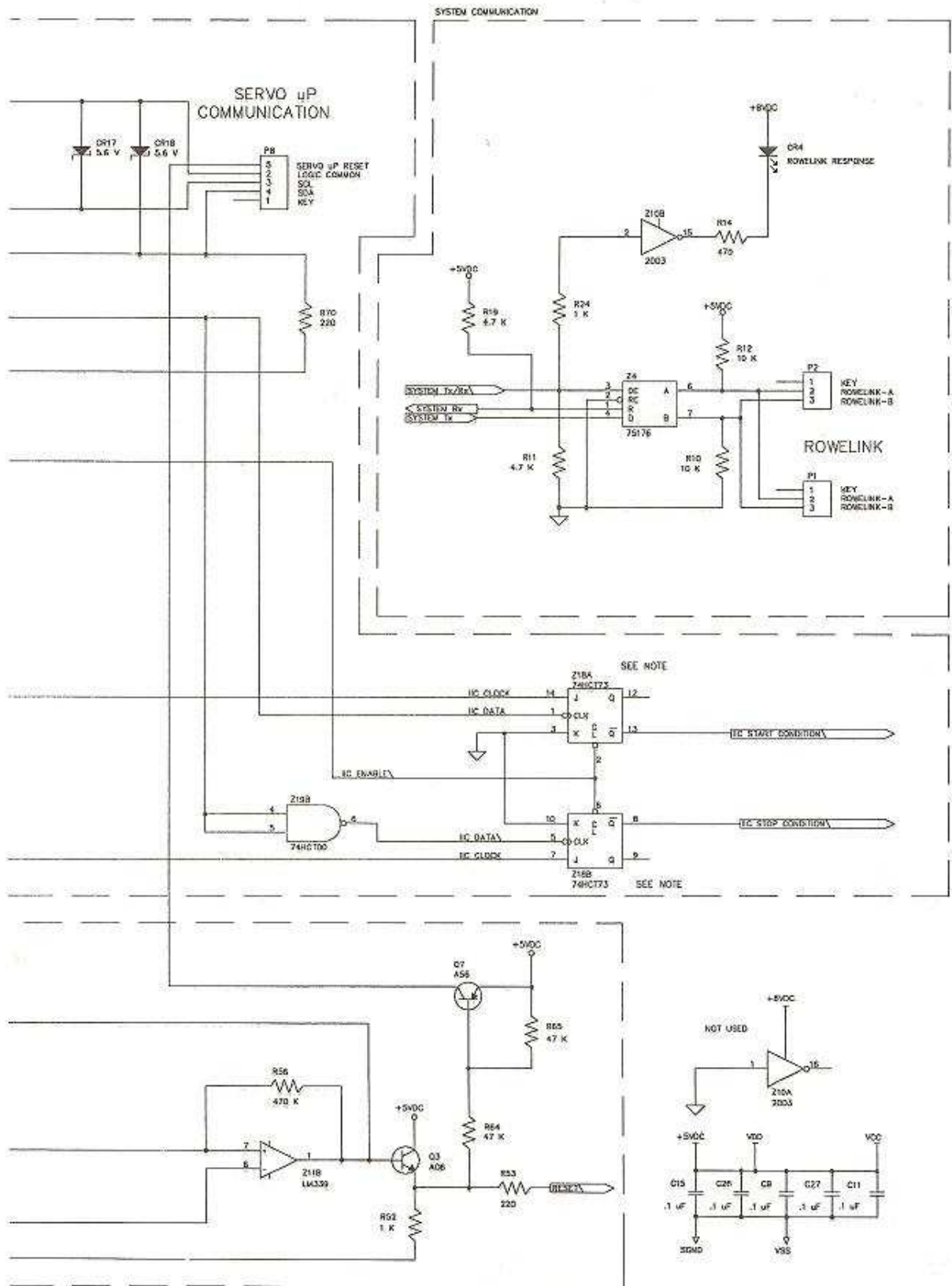

NOTE:  
 WHEN Z1 IS A 6803P-1  
 USE ONLY HGT I.C.'S  
 FOR Z18 & Z20.

For Equivalent Engineering Drawing See 61030603-Q2 A

Figure 5-13B. Mechanism Control Assembly Schematic, Sheet 2

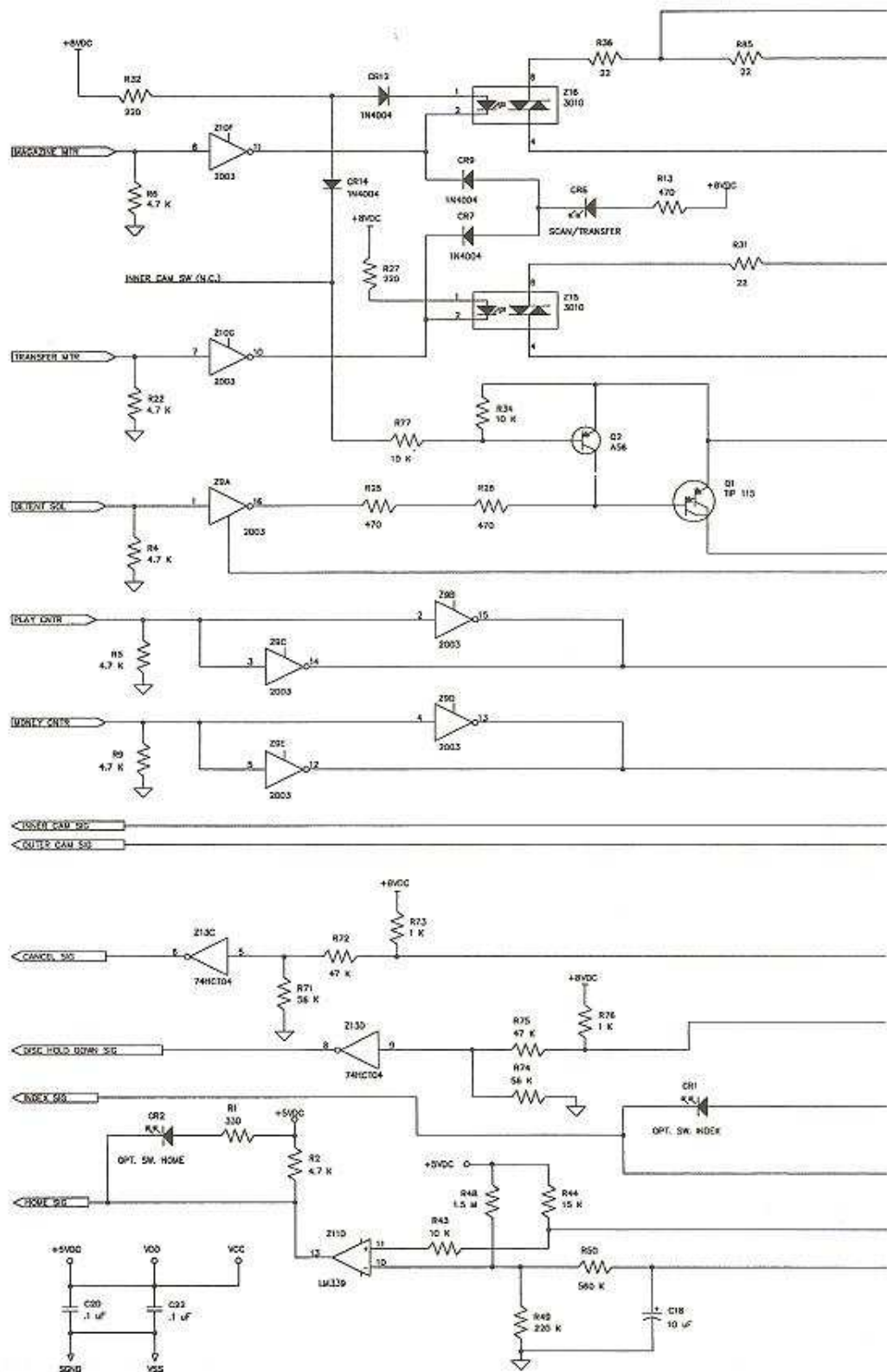



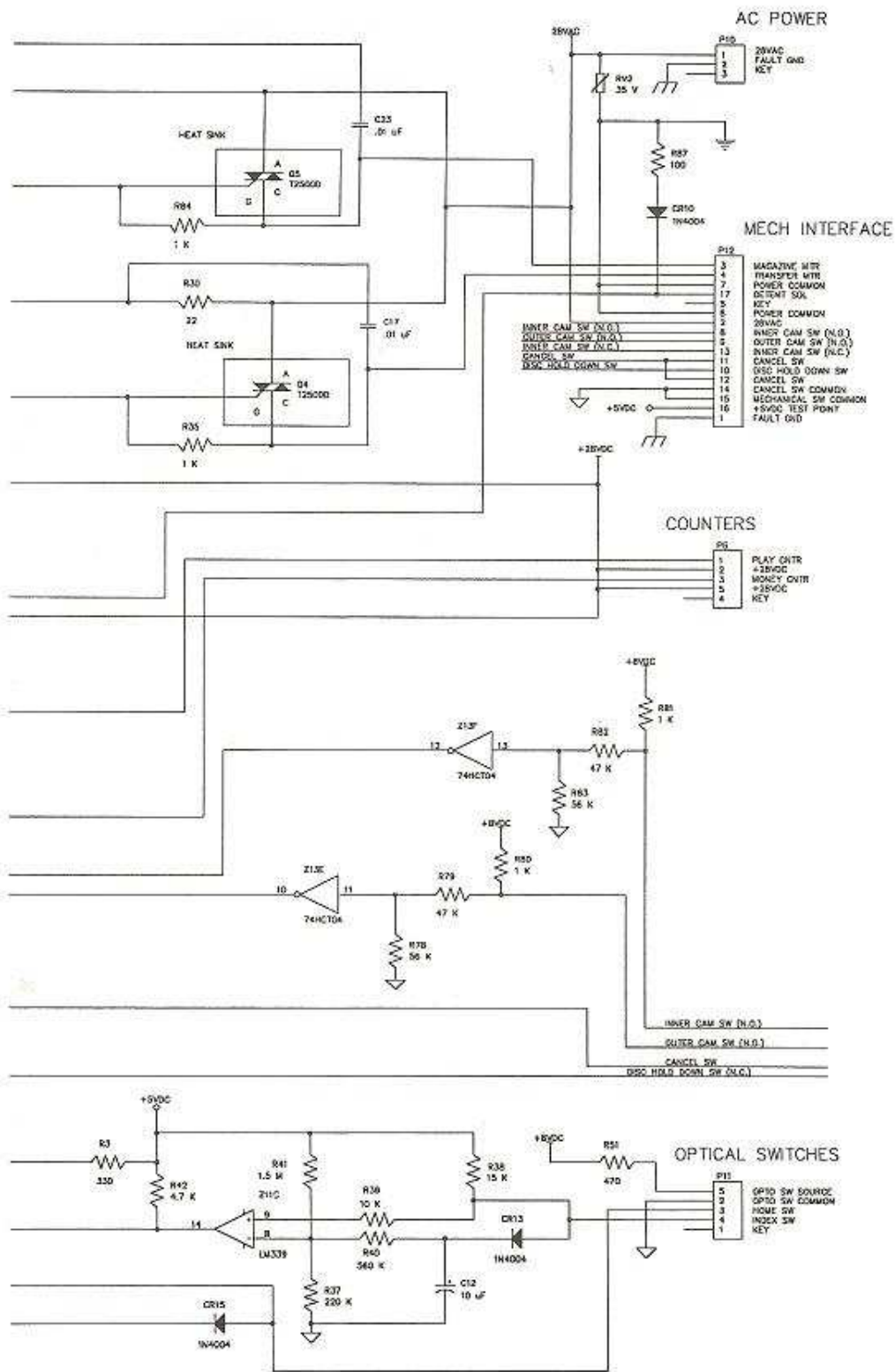

For Equivalent Engineering Drawing See 61030603-G2 A

Figure 5-13B. Mechanism Control Assembly Schematic, Sheet 3

**CD-100A Mech. Controller IC Power And Common Pin Chart**

Ref.	Generic Part #	Power		Common	
		+5 VDC	+8 VDC	Logic	Power
Z1	6803P-1	7	—	1	—
Z2	74HCT00	14	—	7	—
Z3	74HCT04	14	—	7	—
Z4	75176	8	—	5	—
Z5	27256-20	28	—	14	—
Z6	6116/6264/62256-20	28	—	14	—
Z7	74HCT373	20	—	10	—
Z8	74LS374	20	—	10	—
Z9	2003	—	—	8	—
Z10	2003	—	—	8	—
Z11	LM339	—	3	12	—
Z12	74HCT151	16	—	8	—
Z13	74HCT04	14	—	7	—
Z14	74HCT138	16	—	8	—
Z15	3010	—	—	—	—
Z16	3010	—	—	—	—
Z17	74HCT151	16	—	8	—
Z18	74HCT73	4	—	11	—
Z19	74CT00	14	—	7	—
Z20	74HCT73	4	—	11	—
Z21	74HC125	14	—	7	—

For Equivalent Engineering Drawing See 61030603-G2 A

**Figure 5-13B. Mechanism Control Assembly Schematic, Sheet 4**

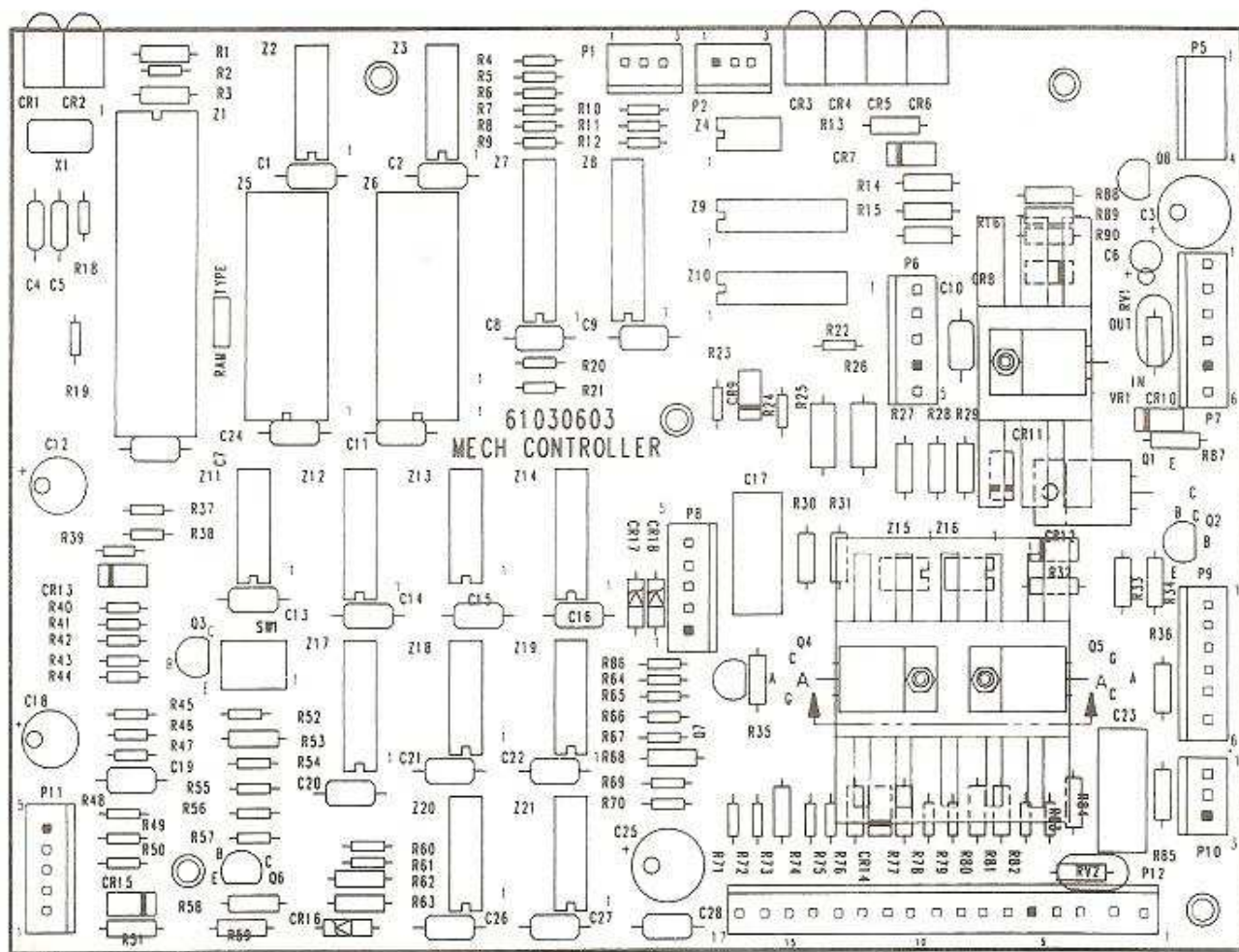

Figure 5-13C. Mechanism Control Assembly Circuit Board Layout



# COMPONENT LIST FOR MECHANISM CONTROL BOARD (61030603-F)

C1	Capacitor - Monolithic Ceramic	.1 mf	70028511
C2	Capacitor - Monolithic Ceramic	.1 mf	70028511
C3	Capacitor - Electrolytic	100 mf	70023814
C4	Capacitor - Monolithic Ceramic	22 pf	70028705
C5	Capacitor - Monolithic Ceramic	22 pf	70028705
C6	Capacitor - Tantalum	.33 mf	70025119
C7	Capacitor - Monolithic Ceramic	.1 mf	70028511
C8	Capacitor - Monolithic Ceramic	.1 mf	70028511
C9	Capacitor - Monolithic Ceramic	.1 mf	70028511
C10	Capacitor - Monolithic Ceramic	.1 mf	70028511
C11	Capacitor - Monolithic Ceramic	.1 mf	70028511
C12	Capacitor - Electrolytic	10 mf	70023808
C13	Capacitor - Monolithic Ceramic	.1 mf	70028511
C14	Capacitor - Monolithic Ceramic	.1 mf	70028511
C15	Capacitor - Monolithic Ceramic	.1 mf	70028511
C16	Capacitor - Monolithic Ceramic	.1 mf	70028511
C17	Capacitor - FILM FOIL	.01 mf	70024013
C18	Capacitor - Electrolytic	10 mf	70023808
C19	Capacitor - Monolithic Ceramic	.1 mf	70028511
C20	Capacitor - Monolithic Ceramic	.1 mf	70028511
C21	Capacitor - Monolithic Ceramic	.1 mf	70028511
C22	Capacitor - Monolithic Ceramic	.1 mf	70028511
C23	Capacitor - FILM FOIL	.01 mf	70024013
C24	Capacitor - Monolithic Ceramic	.1 mf	70028511
C25	Capacitor - Electrolytic	47 mf	70023812
C26	Capacitor - Monolithic Ceramic	.1 mf	70028511
C27	Capacitor - Monolithic Ceramic	.1 mf	70028511
C28	Capacitor - Monolithic Ceramic	.1 mf	70028511

CR1	LED - Block		70035201
CR2	LED - Block		70035201
CR3	LED - Block		70035201
CR4	LED - Block		70035201
CR5	LED - Block		70035201
CR6	LED - Block		70035201
CR7	Diode - Silicon		70035005
CR8	Diode - Silicon		70035005
CR9	Diode - Silicon		70035005
CR10	Diode - Silicon		70035005
CR11	Diode - Silicon		70035005
CR12	Diode - Silicon		70035005
CR13	Diode - Silicon		70035005
CR14	Diode - Silicon		70035005
CR15	Diode - Silicon		70035005
CR16	Diode - Zener	5.1 V	70035526
CR17	Diode - Zener	5.6 V	70035507
CR18	Diode - Zener	5.6 V	70035507

K1 NOT USED

P1	NOT USED		
P2	Wafer - Polarizing	3 CKT	70075003
P3	NOT USED		
P4	NOT USED		
P5	NOT USED		
P6	Wafer - Polarizing	5 CKT	70075005
P7	Wafer - Polarizing	6 CKT	70075006
P8	Wafer - Polarizing	5 CKT	70075005
P9	NOT USED		
P10	Wafer - Polarizing	3 CKT	70075003
P11	Wafer - Polarizing	5 CKT	70075005
P12	Wafer - Polarizing	17 CKT	70075017

Q1	Transistor - Darlington	(PNP)	70030805
Q2	Transistor - Silicon	(PNP)	70030104
Q3	Transistor - Silicon	(NPN)	70030008
Q4	THYRISTOR - Triac		70038102
Q5	THYRISTOR - Triac		70038102
Q6	Transistor - Silicon	(PNP)	70030104
Q7	Transistor - Silicon	(PNP)	70030104
Q8	NOT USED		

Note: All resistors are 1/4 watt 5%, unless otherwise noted.

R1	Resistor - Carbon	330 Ohm	79901331
R2	Resistor - Carbon	4.7 K (1/8 W, 5%)	79905472
R3	Resistor - Carbon	330 Ohm	79901331
R4	Resistor - Carbon	4.7 K (1/8 W, 5%)	79905472
R5	Resistor - Carbon	4.7 K (1/8 W, 5%)	79905472
R6	Resistor - Carbon	4.7 K (1/8 W, 5%)	79905472
R7	Resistor - Carbon	3.3 K (1/8 W, 5%)	79905332
R8	Resistor - Carbon	4.7 K (1/8 W, 5%)	79905472
R9	Resistor - Carbon	4.7 K (1/8 W, 5%)	79905472
R10	Resistor - Carbon	10 K (1/8 W, 5%)	79905103
R11	Resistor - Carbon	4.7 K (1/8 W, 5%)	79905472
R12	Resistor - Carbon	10 K (1/8 W, 5%)	79905103
R13	Resistor - Carbon	470 Ohm	79901471
R14	Resistor - Carbon	470 Ohm	79901471
R15	Resistor - Carbon	470 Ohm	79901471
R16	Resistor - Carbon	330 Ohm	79901331
R17	NOT USED		
R18	Resistor - Carbon	3.3 K (1/8 W, 5%)	79905332
R19	Resistor - Carbon	4.7 K (1/8 W, 5%)	79905472
R20	NOT USED		
R21	Resistor - Carbon	4.7 K (1/8 W, 5%)	79905472
R22	Resistor - Carbon	4.7 K (1/8 W, 5%)	79905472
R23	Resistor - Carbon	1 K (1/8 W, 5%)	79905102
R24	Resistor - Carbon	1 K (1/8 W, 5%)	79905102
R25	Resistor - Metal Film	470 Ohm (1/2 W, 5%)	79904471
R26	Resistor - Metal Film	470 Ohm (1/2 W, 5%)	79904471
R27	Resistor - Carbon	220 Ohm	79901221



**COMPONENT LIST FOR MECHANISM CONTROL BOARD (61030603)**

(Continued)

R28	Resistor - Carbon	5.6 K (1/4 W, 2%)	79902562
R29	Resistor - Carbon	10 K (1/4 W, 2%)	79902103
R30	Resistor - Carbon	22 Ohm	79901220
R31	Resistor - Carbon	22 Ohm	79901220
R32	Resistor - Carbon	220 Ohm	79901221
R33	Resistor - Carbon	1 K	79901102
R34	Resistor - Carbon	10 K	79901103
R35	Resistor - Carbon	1 K	79901102
R36	Resistor - Carbon	22 Ohm	79901220
R37	Resistor - Carbon	220 K (1/8 W, 5%)	79905224
R38	Resistor - Carbon	15 K (1/8 W, 5%)	79905153
R39	Resistor - Carbon	10 K (1/8 W, 5%)	79905103
R40	Resistor - Carbon	560 K (1/8 W, 5%)	79905564
R41	Resistor - Carbon	1.5 Meg (1/8 W, 5%)	79905155
R42	Resistor - Carbon	4.7 K (1/8 W, 5%)	79905472
R43	Resistor - Carbon	10 K (1/8 W, 5%)	79905103
R44	Resistor - Carbon	15 K (1/8 W, 5%)	79905153
R45	Resistor - Carbon	10 K (1/8 W, 5%)	79905103
R46	Resistor - Carbon	10 K (1/8 W, 5%)	79905103
R47	Resistor - Carbon	10 K (1/8 W, 5%)	79905103
R48	Resistor - Carbon	1.5 Meg (1/8 W, 5%)	79905155
R49	Resistor - Carbon	220 K (1/8 W, 5%)	79905224
R50	Resistor - Carbon	560 K (1/8 W, 5%)	79905564
R51	Resistor - Carbon	470 Ohm	79901471
R52	Resistor - Carbon	1 K (1/8 W, 5%)	79905102
R53	Resistor - Carbon	220 Ohm	79901221
R54	Resistor - Carbon	100 K (1/8 W, 5%)	79905104
R55	Resistor - Carbon	220 K (1/8 W, 5%)	79905224
R56	Resistor - Carbon	470 K (1/8 W, 5%)	79905474
R57	Resistor - Carbon	10 K (1/8 W, 5%)	79905103
R58	Resistor - Carbon	150 Ohm	79901151
R59	Resistor - Carbon	100 Ohm	79901101
R60	Resistor - Carbon	27 K (1/8 W, 5%)	79905273
R61	Resistor - Carbon	3.3 K (1/8 W, 5%)	79905332
R62	Resistor - Carbon	10 K	79902103
R63	Resistor - Carbon	10 K	79902103
R64	Resistor - Carbon	47 K (1/8 W, 5%)	79905473
R65	Resistor - Carbon	47 K (1/8 W, 5%)	79905473
R66	Resistor - Carbon	4.7 K (1/8 W, 5%)	79905472
R67	Resistor - Carbon	4.7 K (1/8 W, 5%)	79905472
R68	Resistor - Carbon	4.7 K	79901472
R69	Resistor - Carbon	220 Ohm (1/8 W, 5%)	79905221
R70	Resistor - Carbon	220 Ohm (1/8 W, 5%)	79905221
R71	Resistor - Carbon	56 K (1/8 W, 5%)	79905563
R72	Resistor - Carbon	47 K (1/8 W, 5%)	79905473
R73	Resistor - Carbon	1 K	79901102
R74	Resistor - Carbon	56 K (1/8 W, 5%)	79905563
R75	Resistor - Carbon	47 K (1/8 W, 5%)	79905473
R76	Resistor - Carbon	1 K	79901102
R77	Resistor - Carbon	10 K	79901103
R78	Resistor - Carbon	56 K (1/8 W, 5%)	79905563



R79	Resistor - Carbon	47 K (1/8 W, 5%)	79905473
R80	Resistor - Carbon	1 K	79901102
R81	Resistor - Carbon	1 K	79901102
R82	Resistor - Carbon	47 K (1/8 W, 5%)	79905473
R83	Resistor - Carbon	56 K (1/8 W, 5%)	79905563
R84	Resistor - Carbon	1 K	79901102
R85	Resistor - Carbon	22 Ohm	79901220
R86	Resistor - Carbon	100 Ohm (1/4 W, 5%)	79901101
R87	Resistor - Carbon	100 Ohm (1/4 W, 5%)	79901101
R88	NOT USED		
R89	NOT USED		
R90	NOT USED		
RV1	Varistor - Metal Oxide	11 V	70037505
RV2	Varistor - Metal Oxide	35 V	70037506
SW1	NOT USED		
VR1	Regulator - Voltage		70036505
X1	Crystal - Quartz (4.9152 MHZ)		25167313
Z1	IC - Microprocessor (63A03R OR 6803-1)		70039125
Z2	IC - HCT (QUAD 2 Input NAND)	OR	70039128
Z3	IC - HCT (HEX Inverter)		79930000
Z4	IC - Transceiver (RS-485)		79930004
Z5	IC - 32K X 8 EPROM (27256-20)		70037801
Z6	IC - CMOS RAM (8K X 8)		70038318
Z7	IC - HCT (Octal D-Type)		70036604
Z8	IC - LS (Octal Edge Triggered FF)		79930373
Z9	IC - Darlington Array		70037111
Z10	IC - Darlington Array		70036901
Z11	IC - QUAD Comparator		70036901
Z12	IC - HCT (8 Input Data SEL)		70036801
Z13	IC - HCT (HEX Inverter)		79930151
Z14	IC - HCT (3-To-8 Line Decoder)		79930004
Z15	IC - OPTO Triac		79930138
Z16	IC - OPTO Triac		70033703
Z17	IC - HCT (8 Input Data SEL)		70033703
Z18	IC - HCT (DUAL JK Flip-Flop)		79930151
Z19	IC - HCT (QUAD 2 INPUT NAND)		79930073
Z20	IC - HCT (DUAL JK Flip-Flop)		79930000
Z21	IC - HC (Quad Buffer)		79930073
			79940125

This page intentionally left blank.